

VJ-1627MH

Operation Manual

Operations and Maintenance Methods

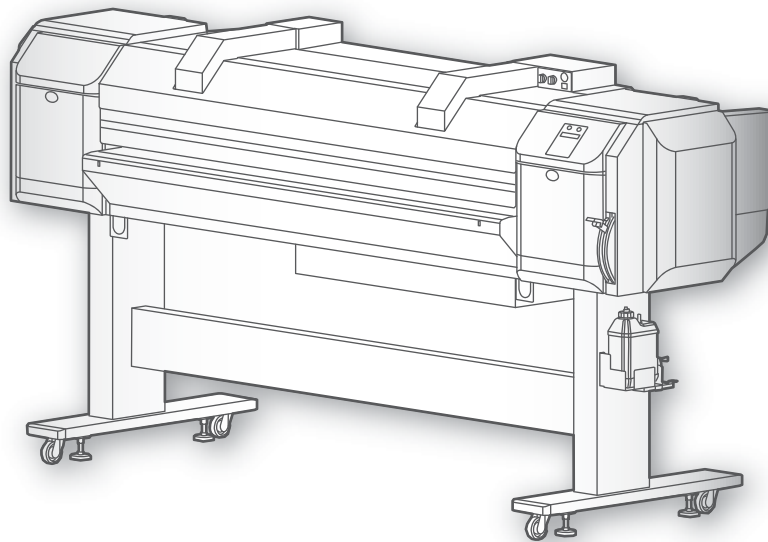

-
- Unauthorized copying or duplication of the whole or part of the contents of this manual is prohibited.
 - Every care has been taken in writing the contents of this manual, but please contact MUTOH or the dealer you purchased the product from if you find any unclear, erroneous or otherwise unsatisfactory content in the manual.
 - Please be aware that MUTOH will not be liable in any way for failures or accidents that result from handling or operating the printer according to any procedures other than those set forth in this manual.
 - Company names and product names that appear in this manual are registered trademarks of the respective companies.

For Users in Europe



The CE marking is a mandatory European marking for certain product groups to indicate conformity with the essential health and safety requirements set out in European Directives.

By affixing the CE marking, the manufacturer, his authorized representative, or the person placing the product on the market or putting it into service ensures that the item meets all the essential requirements of all applicable EU directives and that the applicable conformity assessment procedures have been applied.

For Users in the United States

This equipment has been tested and found to comply with the limits for a Class A digital device, pursuant to Part 15 of the FCC Rules.

These limits are designed to provide reasonable protection against harmful interference when the equipment is operated in a commercial environment.

This equipment generates, uses, and can radiate radio frequency energy and, if not installed and used in accordance with the instruction manual, may cause harmful interference to radio communications.

Operation of this equipment in a residential area is likely to cause harmful interference in which case the user will be required to correct the interference at his own expense.

Chapter 1 Basic Operations

Introduction	9
Name of each part.....	9
Menu chart.....	13
System configurations of this product.....	17
Connecting to a Computer.....	19
Displaying the Printing Preferences screen of printer driver	20
Launching/Displaying/Finishing MUTOH Status Monitor (MSM).....	21
Launching Layout and Print Tool 2	22
Launching MUTOH Layer Editor.....	22
Displaying Help	23
Printing area	23
Requirements for usable media	24
Cautions in using this product	25
Head strike prevention sensor	27
Powering ON / OFF	29
Turning the power ON.....	29
Turning the power OFF	29
Sleep Mode	31
Starting Sleep Mode	31
Loading the media	34
Loading a roll media in the printer	34
Loading a rigid media in the printer.....	39
Nozzle check and cleaning	43
Nozzle check	43
Cleaning	45
Setting the Printing Precision	46
Print quality adjustment	46
Media feed adjustment	48
Operating from Operation panel	49
Feeding and cutting media	49
Pausing / Restarting printing.....	50
Canceling printing.....	50
Starting printing during warming up	50
What you can do on the operation panel during printing	51

Chapter 2 Advanced Operations

Introduction	55
Operating the keys to use the menus	55
Panel setup menu	56
Menu 1: Sleep Mode	60
Menu 2: User Type	61
Menu 3: Setup	75
Set 1: Spitting	75
Set 2: Side Margin	76
Set 3: Take-up	77
Set 4: Media Location	77
Set 5: Origin	78
Set 6: Standby Heating	79
Set 7: Head Travel	79
Set 8: Multi Strike	79
Set 9: Slant Check	79
Set 10: Auto Cleaning	80
Set 11: Roll Length	82
Set 12: FrontInterlace	83
Set 13: BtmInterlace	83
Set 14: Ink Status	84
Set 15: Life Times	84
Set 16: Header Dump	85
Set 17: Start Feed	85
Set 18: Obstacle Check	86
Set 19: Initialization	86
Set 20: Temporary	86
Menu 4: Test Print	87
Test 1: Nozzle Check	87
Test 2: Nozzle Check B	87
Test 3: Mode Print	88
Test 4: Setup List	88
Test 5: Palette	89
Menu 5: Cleaning	89
Menu 6: Menu Option	90

Menu 7: Maintenance	91
Maintenance 1: Daily Maintenance	91
Maintenance 2: Long Storage	91
Maintenance 3: Cap Out	92
Maintenance 4: Longstore	92
Maintenance 5: Ink Replace	92
Maintenance 6: Wash Replace	92
Maintenance 7: Color Maintenance	93
Menu 8: Version	93
Menu 9: Initial	94
Initial 1: Language	94
Initial 2: Length	94
Initial 3: IP Address	94
Initial 4: Subnet Mask	95
Initial 5: Gateway	95
Initial 6: Alert Buzzer	95
Menu 10: Job Status	96

Chapter 3 Maintenance

Maintenance	98
Agitating ink	99
Agitating ink	99
Checking and replacing ink	101
Checking ink level	101
When it becomes time to replace ink	102
Replacing ink	102
Replacing Adapter's plug for High capacity ink pack adapter	104
Emptying waste fluid tank	105
Emptying waste fluid tank	105
Daily Maintenance	108
Flow of Daily Maintenance	108
Preparing for Daily Maintenance	109
Performing Daily Maintenance	111
Continuously using printer after daily maintenance	118
Cleaning each part	120
Head cleaning	120
Inside cleaning	122

Replacing consumable parts	123
Replacing absorption material for the flushing box.....	123
Replacing the cleaning wiper.....	127
Moving or transporting the printer	129
Moving the printer	129
Transporting the printer.....	130
Long Storage and Initial Charge	131
If not using the printer for a long period of time.....	131
Performing Long Storage.....	132
Performing initial charging after head cleaning	136

Chapter 4 Appendix

Messages and Error Messages	140
Status messages	140
Error message display and remedies	143
Error requiring restart	146
Troubleshooting	147
Installation and initial setup troubleshooting.....	147
Boot-up troubleshooting.....	148
Media-related troubleshooting	149
Printing-related troubleshooting	151
The media is jammed	154
Specifications of this product	156
List of specifications.....	156
Options / Supply list	158
Revision History	158

Chapter 1 Basic Operations

Introduction	9
Name of each part	9
Menu chart	13
System configurations of this product	17
Connecting to a Computer	19
Displaying the Printing Preferences screen of printer driver	20
Launching/Displaying/Finishing MUTOH Status Monitor (MSM)	21
Launching Layout and Print Tool 2	22
Launching MUTOH Layer Editor	22
Displaying Help	23
Printing area	23
Requirements for usable media	24
Cautions in using this product	25
Head strike prevention sensor	27
Powering ON / OFF	29
Turning the power ON	29
Turning the power OFF	29
Sleep Mode	31
Starting Sleep Mode	31
Loading the media	34
Loading a roll media in the printer	34
Loading a rigid media in the printer	39
Nozzle check and cleaning	43
Nozzle check	43
Cleaning	45
Setting the Printing Precision	46
Print quality adjustment	46
Media feed adjustment	48

Operating from Operation panel49

- Feeding and cutting media 49
- Pausing / Restarting printing 50
- Canceling printing 50
- Starting printing during warming up 50
- What you can do on the operation panel during printing..... 51

Introduction

Name of each part

Printer's main body (Front side)

Front cover

Open and close this cover when media is loaded or jammed.

Maintenance cover L

Open and close this cover when cleaning or replacing consumables.

Media guide

This is a passage for the media.

Stand

Adjuster

Blower heater

Blows hot air to accelerate drying of media.

Blower heater Operation panel

⇒ Heater Operation panel P. 12

Operation panel

⇒ Operation panel P. 11

Maintenance cover R

Open and close this cover when cleaning or replacing consumables.

Media loading lever

Used for fixing or releasing the media.

Lower Lever further to fix the media firmly.

Waste fluid tank

Used for collecting waste fluid discharged from the printer.

Remove the waste liquid before it becomes full.

Carriage

Contains the print head, the LED pointer.

Pressurizing rollers

Press and hold the whole media when printing.

Platen

Media is printed on here. There is an adsorption fan inside.

Head strike prevention sensor

Avoid a head strike while printing.

Media cut groove

Used to cut media straight.

Media holder

Located at the edge of the media and it protects the media from being lifted. (located on both edges.)

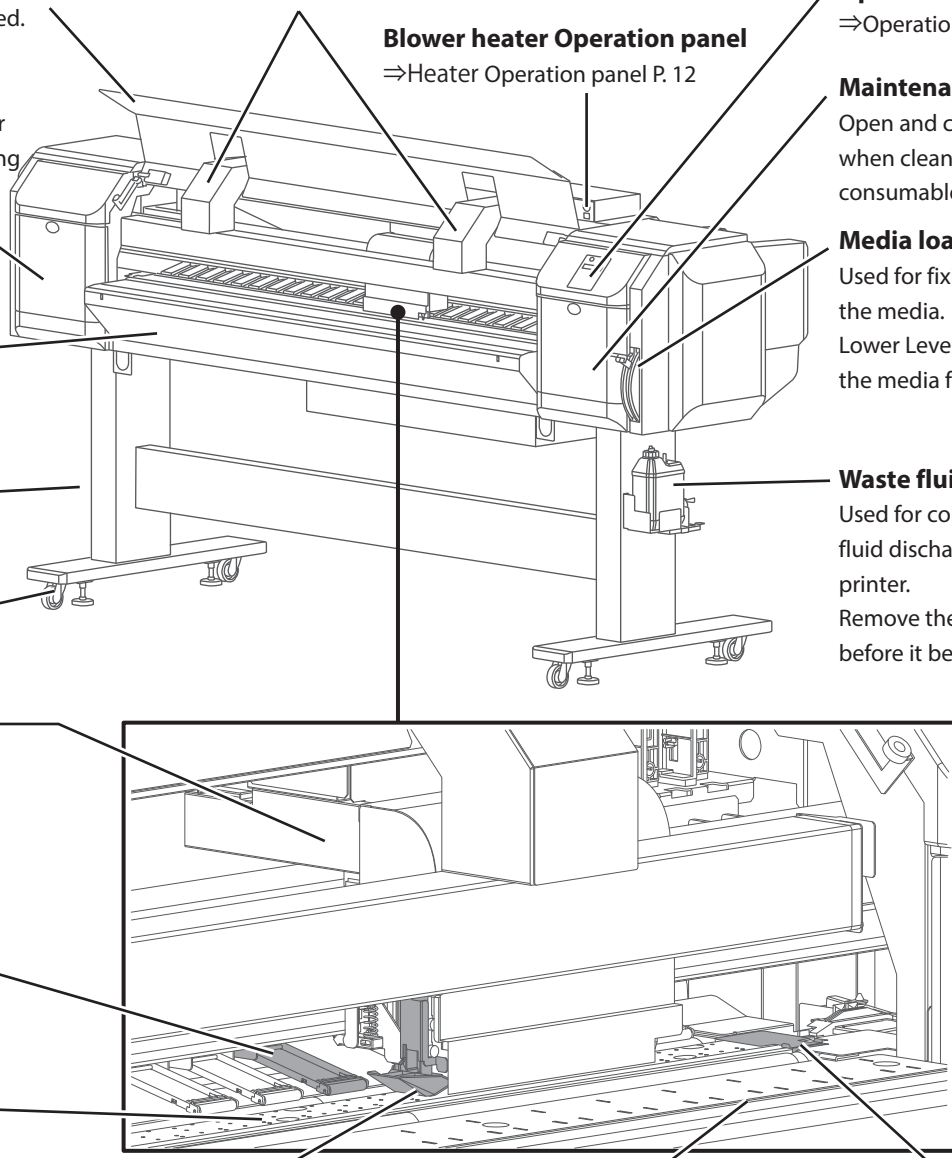

Printer's main body (Rear side)

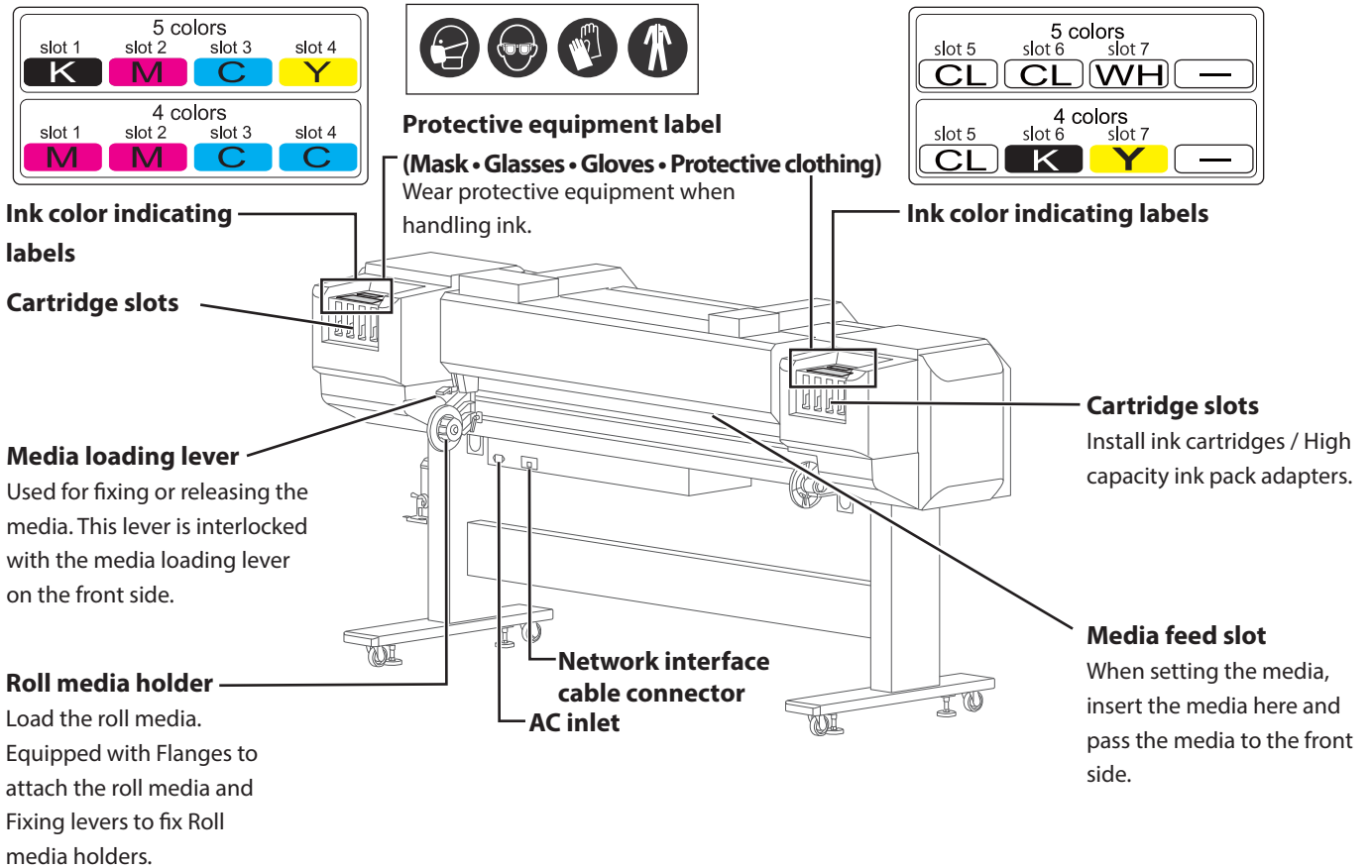

Operation panel

[Power] button

- Pressing this turns the power on. Lights steady in blue when the power is on.
- Pressing this once more turns the power off. Is unlit when the power is off.
- Flashes while data is being received, in the sleep mode, and at other times.

[Reference]

The  symbol means "standby". Even when the power button is not turned on, the printer consumes a tiny amount of power so long as the power cable is connected. This state is referred to as the power being "off" in this Manual.

[Heater Link] indicator

Lights steady green when the Blower heater is set to "Printer Link".

[Origin] indicator

Lights steady green when the Origin setting is activated.

[Media Type] indicator

- Roll Media: "Roll" indicator is ON.
- Rigid Media: "Rigid" indicator is ON.

[Menu] key

Used for accessing and exiting the menu.

[Pause] / [Cancel] key

- Press this key to pause printing.
- Holding this key pressed down for two seconds or longer will cancel the print job and delete the data received.

When setting the menu:

- Cancels a change of a setting value.

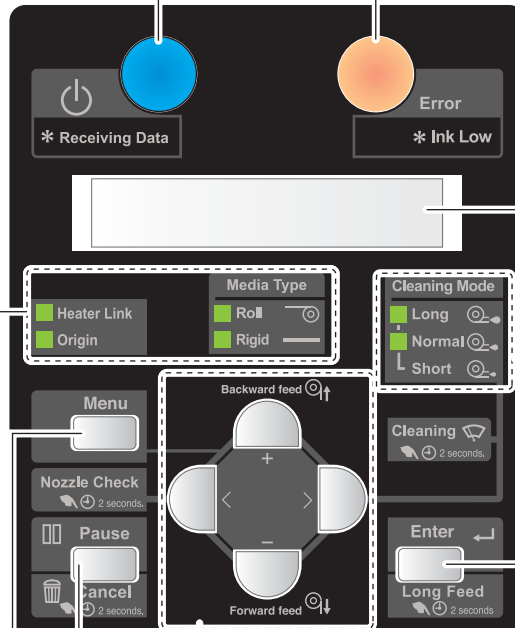

Error indicator

- Lights up in orange when an error has occurred or a cover is open.
- Flashes when the ink is low.

Display

Displays the printer status, setting menu, errors and so on.

[Cleaning Mode] indicators

Light steady green to indicate the head cleaning mode.

[Enter] key

When you have set a media in place, pressing and holding this down for two seconds or longer will run a media feed.

When setting the menu:

- Press this to go to the menu item you select.
- Press this to confirm a set value.

[+] key / [Backward feed] key

Media is fed in the backward direction.

When setting the menu:

- Press this to move to another menu item
- Press this to change a set value.

[-] key / [Forward feed] key

Media is fed in the forward direction.

When setting the menu:

- Press this to move to another menu item
- Press this to change a set value.

[<] key / [Nozzle Check] key

Pressing and holding this down for two seconds or longer will run a nozzle check.

When setting the menu:

- Press this to change a set value.

[>] key / [Cleaning Mode] key

• For changing the cleaning mode.

• Pressing and holding this down for two seconds or longer will execute head cleaning.

When setting the menu:

- Press this to move to a lower level of menu items.
- Press this to change a set value.

Heater Operation panel

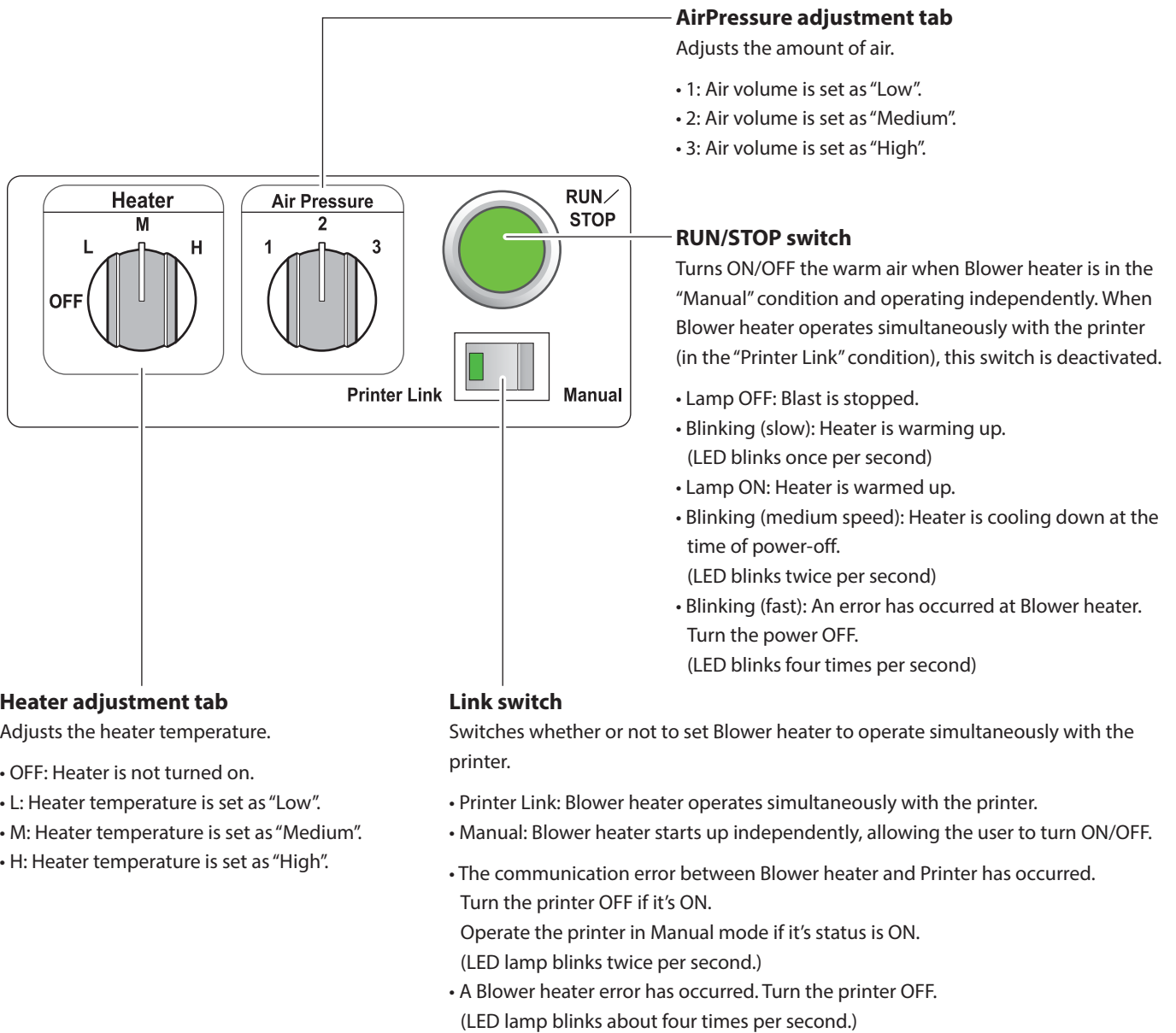

Note

If an error has occurred at Blower heater in the Printer Link mode, "Heater Error" is displayed on Operation panel as well.

Menu chart

Setting menu 1

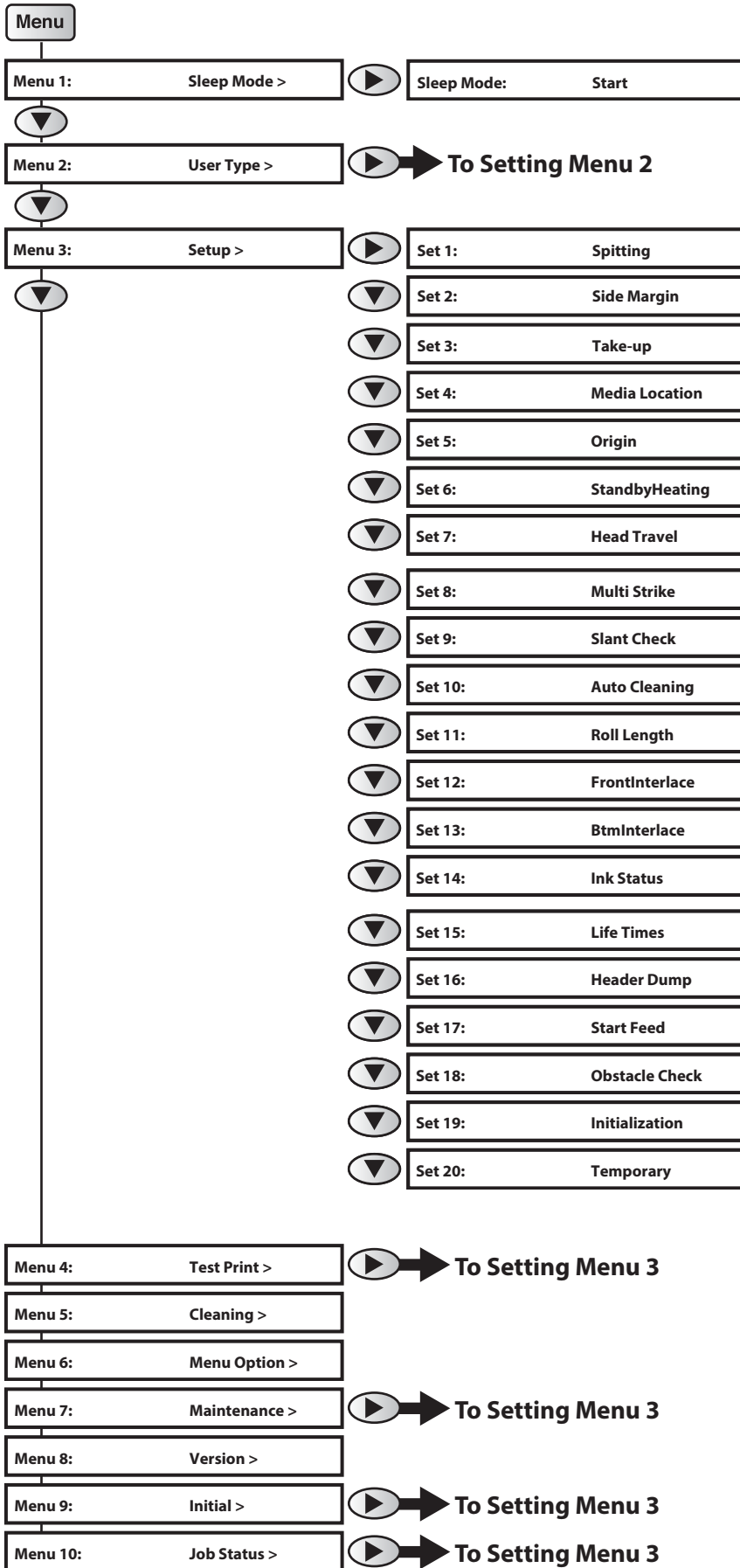

Setting menu 2

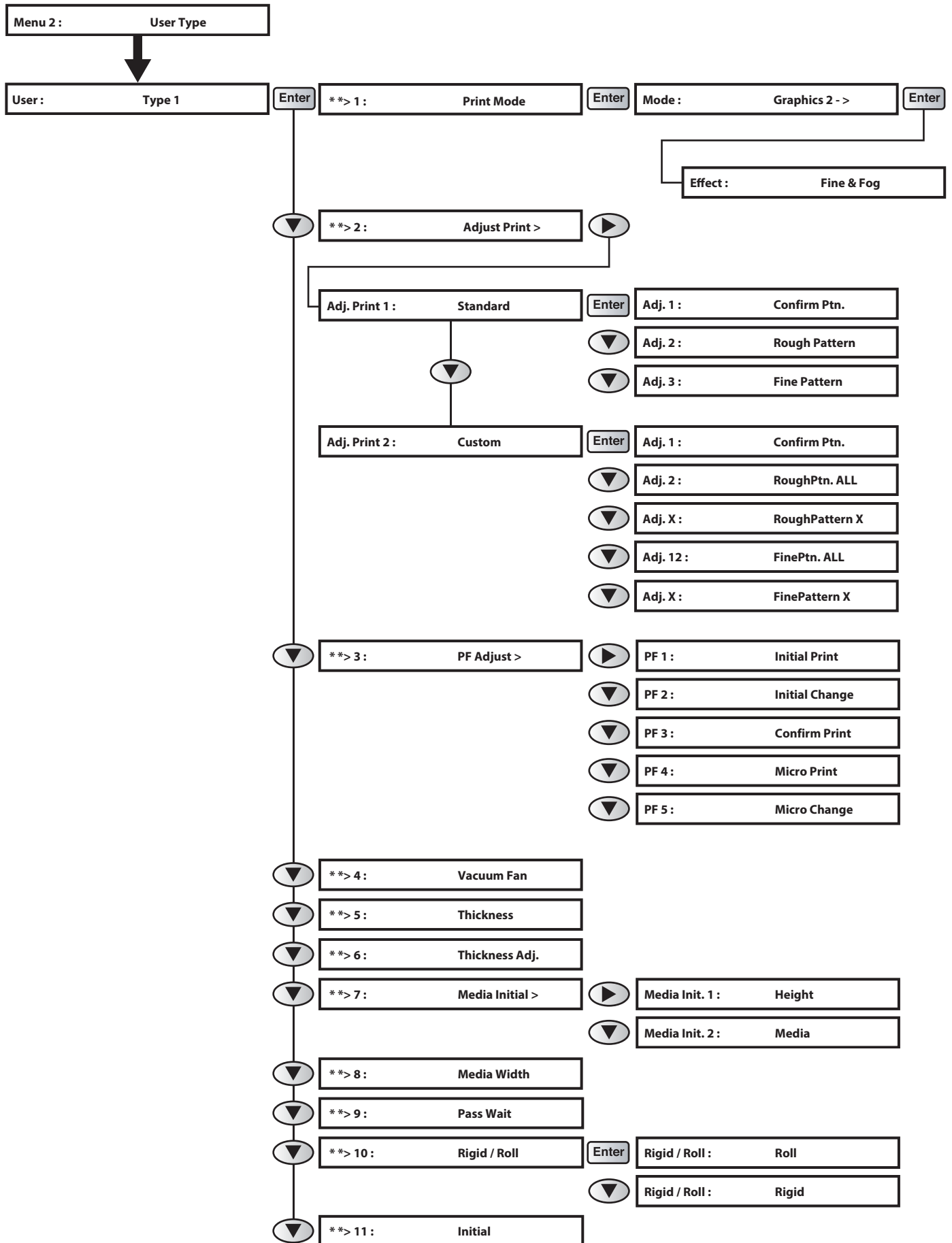

Setting menu 3

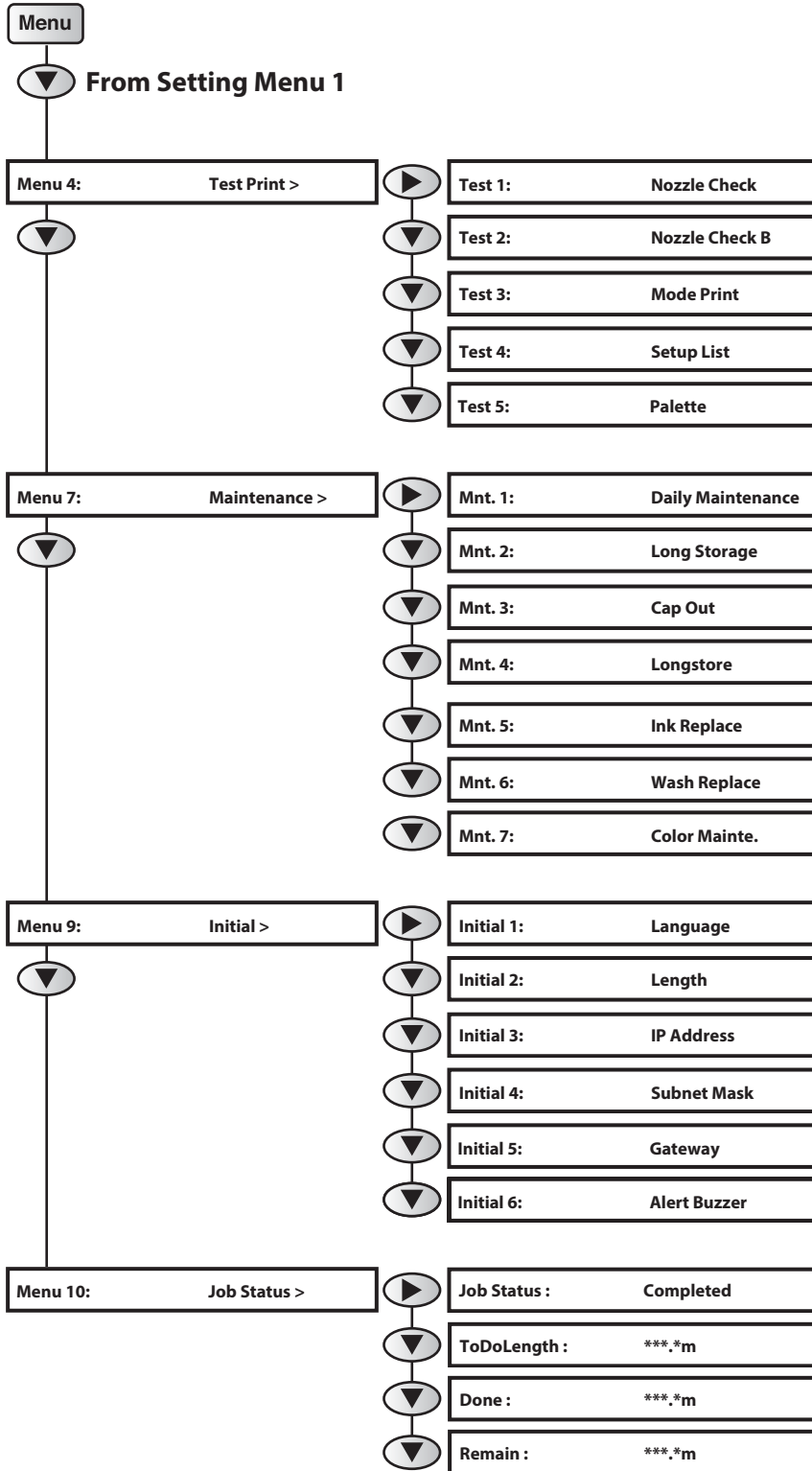

Menu during printing

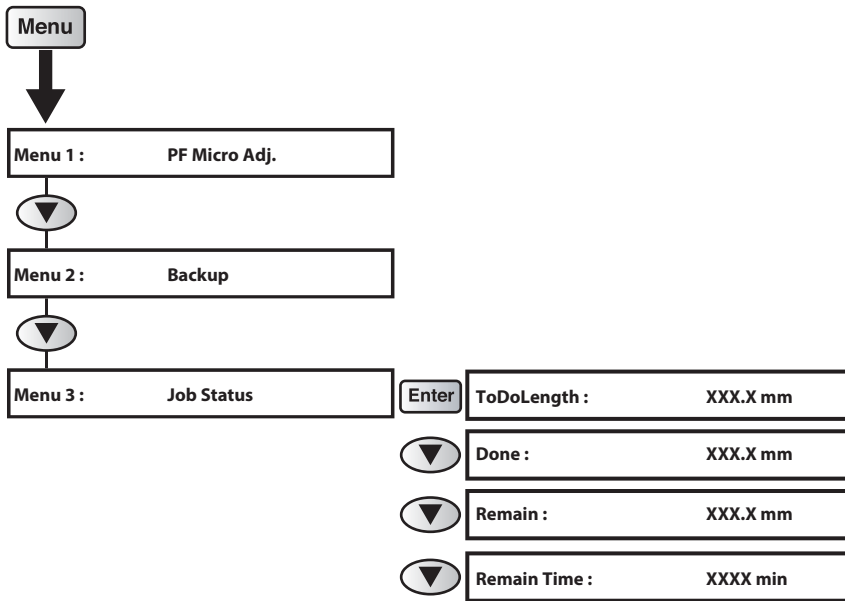

System configurations of this product

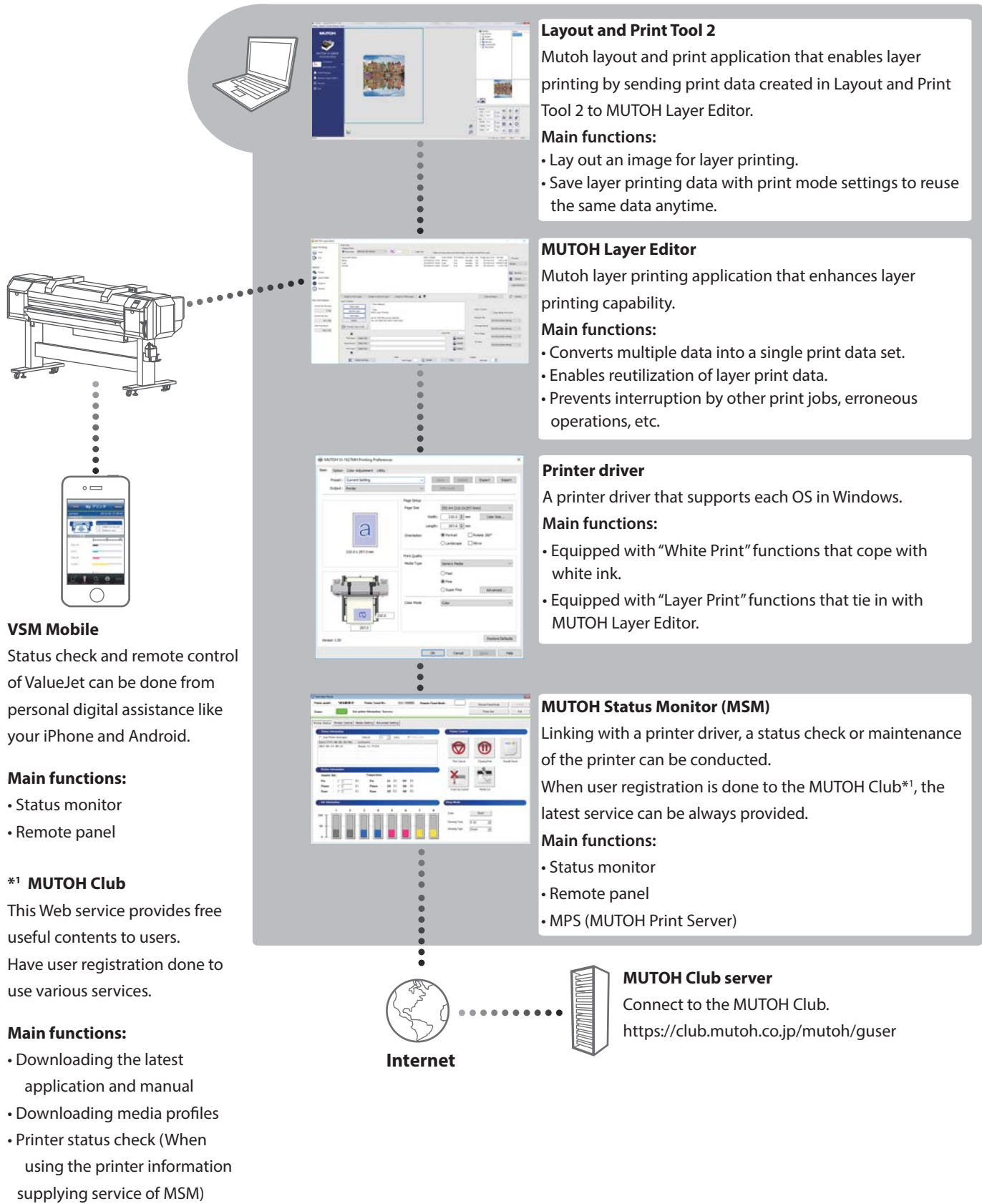

Layout and Print Tool 2

Mutoh layout and print application that enables layer printing by sending print data created in Layout and Print Tool 2 to MUTOH Layer Editor.

Main functions:

- Lay out an image for layer printing.
- Save layer printing data with print mode settings to reuse the same data anytime.

MUTOH Layer Editor

Mutoh layer printing application that enhances layer printing capability.

Main functions:

- Converts multiple data into a single print data set.
- Enables reutilization of layer print data.
- Prevents interruption by other print jobs, erroneous operations, etc.

Printer driver

A printer driver that supports each OS in Windows.

Main functions:

- Equipped with "White Print" functions that cope with white ink.
- Equipped with "Layer Print" functions that tie in with MUTOH Layer Editor.

MUTOH Status Monitor (MSM)

Linking with a printer driver, a status check or maintenance of the printer can be conducted.

When user registration is done to the MUTOH Club*¹, the latest service can be always provided.

Main functions:

- Status monitor
- Remote panel
- MPS (MUTOH Print Server)

VSM Mobile

Status check and remote control of ValueJet can be done from personal digital assistance like your iPhone and Android.

Main functions:

- Status monitor
- Remote panel

*1 MUTOH Club

This Web service provides free useful contents to users. Have user registration done to use various services.

Main functions:

- Downloading the latest application and manual
- Downloading media profiles
- Printer status check (When using the printer information supplying service of MSM)



Internet



MUTOH Club server



Connect to the MUTOH Club.

<https://club.mutoh.co.jp/mutoh/guser>

Appropriate Use of Layout and Print Tool 2 and MUTOH Layer Editor

This printer contains two print application; Layout and Print Tool 2 and MUTOH Layer Editor.
To perform layer printing, please use Layout and Print Tool 2.

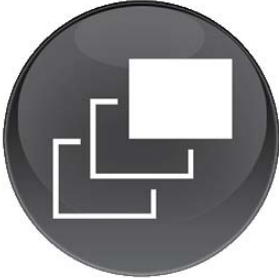
Each print application has following features.

	Layout and Print Tool 2	MUTOH Layer Editor
		
Functions	<p>Enables to print more than one image layer by layer on the same media. Users can edit layer printing layout and save them.</p>	<ul style="list-style-type: none"> • Receives print data from the printer driver. Users can assign the received data to each layer to perform layer printing. • To create print data file, use Layout and Print Tool 2 or other graphic applications.
Intended use	<ul style="list-style-type: none"> • Suitable for small print production or adding text to an image. • Recommended to use MUTOH Layer Editor for large print production. 	<p>Saves print data with format converted for the printer to print soon after sending from MUTOH Layer Editor and efficiently reprint the same data.</p>
Image printing (PNG/TIFF)	✓	—
Single layer printing (Print 2 layers in one pass)	—	✓
Change printer settings on output data	—	✓ (Change carriage speed, vacuum fan and more)

 **Note**

For more details of layer printing and supported file format, see the Layout and Print Tool 2 Operation Manual and MUTOH Layer Editor Operation Manual.

Connecting to a Computer

Important!

Make sure your computer meets the following requirements.

- OS: Windows 10, Windows 8/8.1, Windows 7

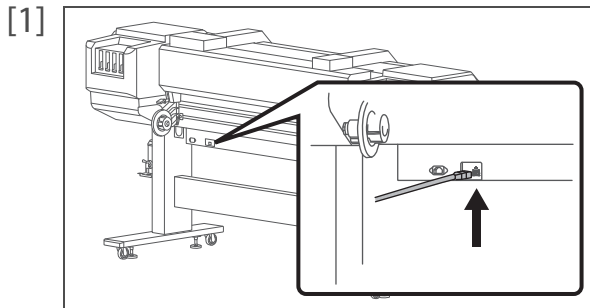

Connect the Ethernet cable to the product.

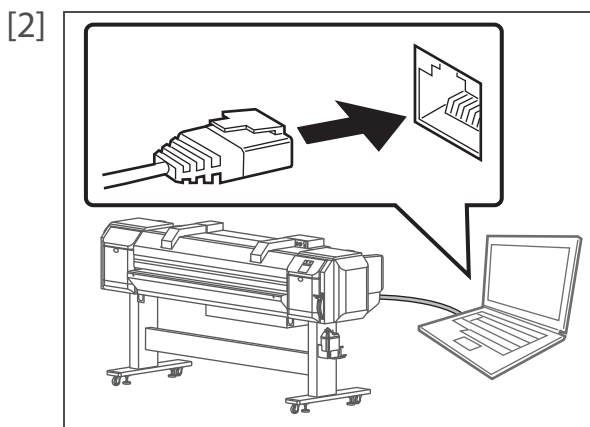

Connect the Ethernet cable to the computer.

[3] Use the printer operation panel to set the IP address, subnet mask and gateway.

 ["Initial 3: IP Address" P. 94](#), ["Initial 4: Subnet Mask" P. 95](#), ["Initial 5: Gateway" P. 95](#)

Note

- The above illustration is the example of peer-to-peer connection between this product and computer. Connection method differs depending on the usage environment.
- If you use the product with a LAN, connect the cable so that the computer and printer are on the same subnet.

Displaying the Printing Preferences screen of printer driver

[1] Windows 10

Click [Start], [All Apps], [Windows System], then [Control Panel].
In the screen that appears, click [Devices and Printers].

Windows 8 / Windows 8.1

Display the charm bar on Desktop, and click [Settings]. Click [Control Panel] - [View devices and printers].

Windows 7

Click [Start] - [Devices and Printers].

[2]

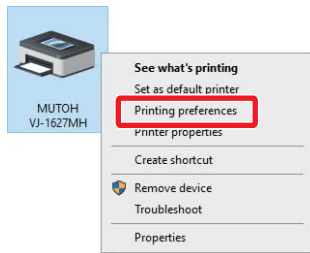

Right click the "MUTOH VJ-1627MH" icon and click [Printing preferences].

- The "Printer Configuration" dialog box opens only at the first time.
- The Printing Preferences screen of printer driver opens from the second time.

[3]

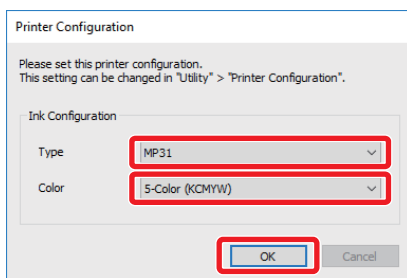

Select the ink type and the ink configuration settings and click [OK].

- After clicking, the Printing Preferences screen of printer driver opens.



Note

If you use the Windows printer driver, make sure to select the ink type and the ink configuration settings of your printer.

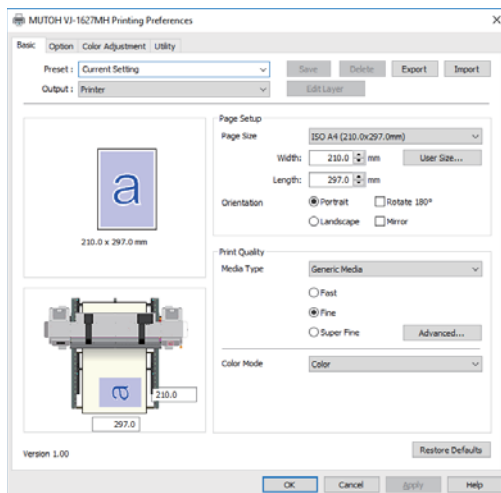

Printing Preferences screen of printer driver

Launching/Displaying/Finishing MUTOH Status Monitor (MSM)

Launching MSM



Windows 8 / Windows 8.1

- In the [Start] screen, click [Desktop].
- Double click the MSM icon on the Desktop.

Windows 10 / Windows 7

Double click the MSM icon on the Desktop.

Note

Launching from the Start Menu of Windows

- Windows 8 / Windows 8.1
Right click somewhere the [Start] screen tiles are not displayed to display the application bar, and click [All Apps].
- Windows 10 / Windows 7
From the [Start] menu, click [All Programs] (or [All Apps]) - [MUTOH] - [MUTOH Status Monitor].

Displaying MSM

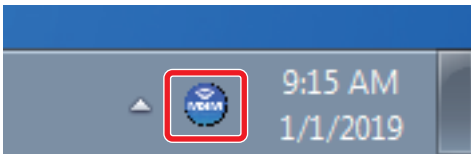

Double click the MSM icon in the task tray.

Displaying remote panel

The remote panel is used to view this product's status or operate.

Click [Remote Panel].

- The remote panel opens.

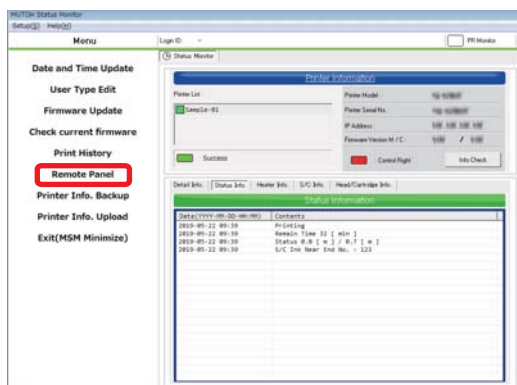

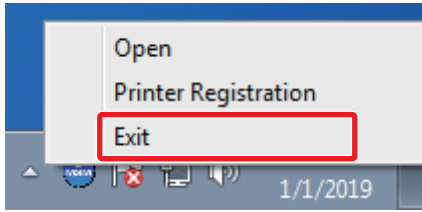

Right click the MSM icon in the task tray, and click [Exit].

Note

When using normally, do not finish MSM. When closing the MSM window, click [Settings] - [Close].

Windows 8.1

Click the Down Arrow in the [Start] screen.
Click [MUTOH Status Monitor].

Launching Layout and Print Tool 2

Windows 8 / Window 8.1

Display the charm bar on the desktop, and then click [Search].

Enter "Layout and Print Tool 2", and then click .

Click the "Layout and Print Tool 2" icon displayed in the search result.

Windows 10 / Windows 7

From the [Start] menu, click [All Programs] (or [All Apps]) – [MUTOH] – [Layout and Print Tool 2] in order.

Launching MUTOH Layer Editor

Windows 8 / Window 8.1

Display the charm bar on the desktop, and then click [Search].

Enter "MUTOH Layer Editor", and then click .

Click the "MUTOH Layer Editor" icon displayed in the search result.

Windows 10 / Windows 7

From the [Start] menu, click [All Programs] (or [All Apps]) – [MUTOH] – [MUTOH Layer Editor] in order.

Displaying Help

A Help menu is available in the printer driver.

Printer driver

Display the Printing Preferences screen of printer driver, and click [Help].

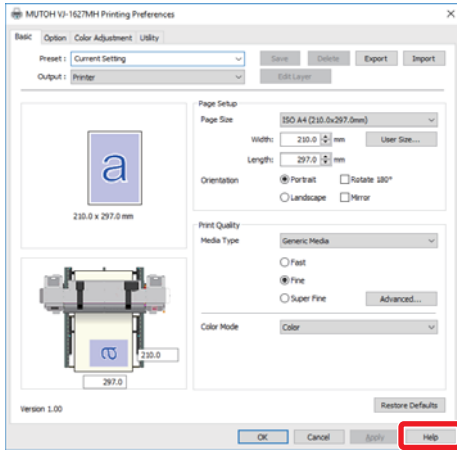

Printing area

Printing is always started from Origin position (print start point).
See the figure below as example.

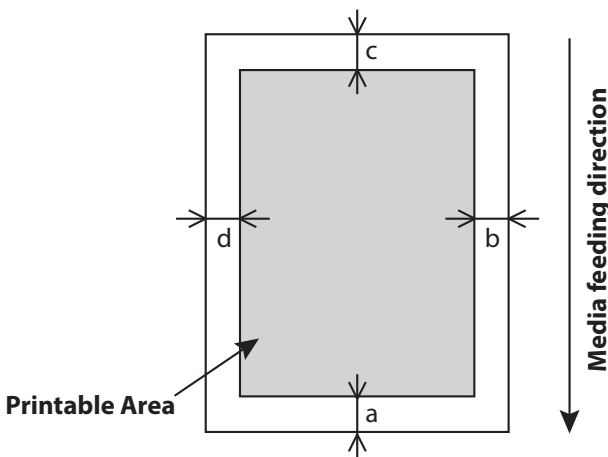

a=5 mm *1
b=5 mm to 25 mm
c=5 mm
d=5 mm to 25 mm

*1 The value of "a" will be 15 mm in the following cases:
• Immediately after media initialization
• When feeding the media by using the [Backward] key

The value of "a" will be 40 mm in the following cases:
• When Media Initial menu is set to "Top&Width"

Requirements for usable media

Media that meet the requirements below can be used with this printer.

Usable sizes

When using Roll media

Outer diameter	150 mm or less
Media tube diameter	2 inches or 3 inches
Weight	30 kg or less
Maximum width	1,625 mm
Minimum width	182 mm
Maximum thickness	16 mm (warpage of less than 1 mm)

When using Rigid media

Length	200 mm to 1,200 mm
Weight	15 kg or less
Maximum width	1,625 mm
Minimum width	182 mm
Maximum thickness	16 mm (warpage of less than 1 mm)



Note

To use rigid media, prepare the media-feed table.

Cautions for handling media

To achieve expected print quality, follow the instructions below.

Failure to follow these instructions could result in damage to the printer.

- Be cautious of expansion and contraction of media from temperature and humidity.
After opening an unopened media, leave the media for approximately 30 minutes to adjust to environments.
- Do not use media with folds, scratches, tears, curvatures, winding curl and weaving.
If the media has folds or curls on the end, use the media holders to hold the media flat on the platen.
- Do not leave a roll media set in this product for a long time.
The media can be curled becoming unsuitable for printing.
When not using for a long time, remove a roll media and store in its original package box.

Cautions in using this product

Do not turn the power off

Use the printer with its power turned permanently on. When you are not using the printer, always leave the power on and put the printer into the sleep mode while not in use. In the sleep mode, the printer will periodically circulate the ink inside the printer and carry out head cleaning automatically. If you do not put the printer into the sleep mode, the ink inside the printer could settle out and/or coagulate, causing poor image quality or printer failure.



If you need to leave the printer unused for extended period of times (more than one month), please contact your local MUTOH dealer.

Agitate the ink bags

Before installing a new ink bag, invert the ink bag back and forth to agitate ink. Periodical ink agitation is also required when prompted on the operation panel. Otherwise, the ink inside the bags settles or coagulates and may cause poor print quality or a malfunction.

Please use this product periodically

It is recommended to use this product once a week. When left unused for a long time, the print head nozzles can get clogged causing damage.

Conduct periodic maintenance

This product requires daily maintenance.

- Perform the Nozzle check before and after printing.
If nozzle missing is found, conduct a head cleaning.
- Make sure to perform daily maintenance after you finish printing for the day.
Failure to perform daily maintenance may affect print quality or result in damage to the printer.
 ["Daily Maintenance" P. 108](#)
- Drain waste fluid in the waste fluid tank periodically before it becomes full.
- When this product is not used for a long time (a week or more), conduct a head cleaning once a week.
- Clean its inside once a month.

Please handle ink bag carefully

- Wear protective equipment (gloves, goggles or eye protection, protective mask, protective clothing) when handling ink.
- Before operation, make sure to read the Material Safety Data Sheet (SDS).
- Do not disassemble Ink bag.
If disassembled, there is a possibility that ink might come into contact with your eyes or skin.
- DO NOT drop or hit an ink bag.
Ink may leak from the bag.
- When handling the ink cartridge (ink bag), be careful not to let the ink get in your eyes or on your skin.
If the ink gets in your eye or on your skin, immediately wash it off with water.
If not, it could cause bloodshot eyes or light inflammation. Should any anomalies occur, immediately seek medical attention.

Some parts need to be replaced periodically

In this product, there are some parts required to be replaced after a long-term use.

- Parts required to be replaced by users:
Absorption material for the flushing box, Cleaning wiper
- Parts required to be replaced by service personnel:
Various motors, Pumps, Print head

Head strike prevention sensor

This printer has the head strike prevention sensor to protect the print head.

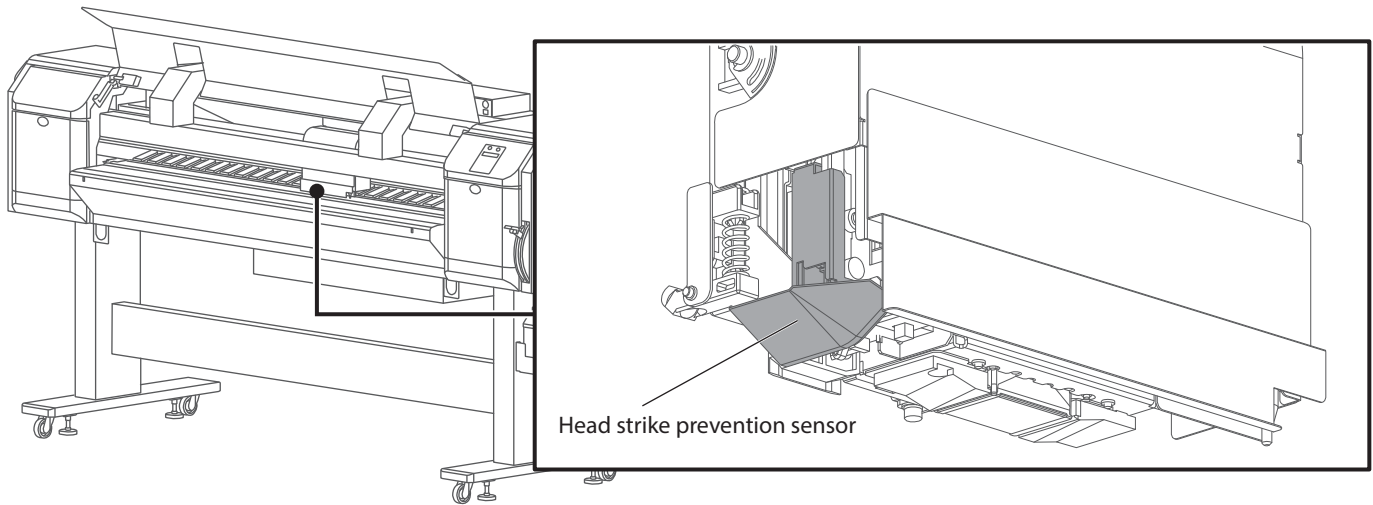

Important!

The sensor is designed to protect the print head from a head strike. It cannot prevent the media from touching the print head due to the roll media warp.

If the media warps, use the media holders or change the vacuum fan setting to hold the media flat on the platen.

👉 ["After loading the media..." P. 37](#), ["***>4: Vacuum Fan" P. 72](#)

When the sensor detects obstacles

During media initialization:

- [1] When it senses obstacles, the carriage stops moving.
 - Then the carriage moves up to the top and goes back to the capping station.
- [2]

Obstacle Detection	- > E
---------------------------	-------

 The message on the left will appear.
- [3] Remove the obstacle and press the [Enter] key.
- [4] Reload the media.

While printing:

- [1] When it senses obstacles, the carriage stops moving.
 - Then the carriage moves up to the top and goes back to the capping station.
- [2]

Obstacle Detection	- > E
---------------------------	-------

 The message on the left will appear.
- [3] Remove the obstacle and press the [Enter] key.
- [4]

Print Restart?	No
-----------------------	-----------

 The message on the left will appear.
 - Press the [Enter] key to cancel printing.

- [5]

Print Restart?	Yes
-----------------------	------------

 To resume the job, use the [+] / [-] key to select the message "Print Restart? Yes", and then press the [Enter] key.
- [6]

Change:	X.X mm	- >
----------------	---------------	---------------

 The message on the left will appear.
 - Use the [+] / [-] key to adjust the head height for the media, and then press the [Enter] key.
- [7]

Is it preserved?	No
-------------------------	-----------

 The message on the left will appear.
 - To enable the value entered only for the current job and not to save the changes, press the [Enter] key.
- [8]

Is it preserved?	Yes
-------------------------	------------

 To overwrite the thickness adjustment value in the user type with the value entered, use the [+] / [-] key to select the message "Is it preserved? Yes", and then press the [Enter] key.
- [9] The printer restarts printing.
 - If the sensor detects an obstacle again, the message "Obstacle Detection ->E" will appear on the panel. Adjust the head height for the media.
 - If this problem persists repeatedly, select the message "Print Restart? No" to cancel the job and check that the sensor works properly.

 **Note**

- When the sensor detects an obstacle, remove it. If the problem persists repeatedly, check that the sensor works properly.
- If ink stains on the bottom of the sensor, follow the steps below to remove it. If the ink deposits, it cannot detect obstacles properly.
 ["Continuously using printer after daily maintenance" P. 118](#), ["How to clean the head strike prevention sensor" P. 115](#)

 **Important!**

Mutoh cannot guarantee the quality of the print when the job was paused or resumed as the head strike prevention sensor was tripped.

Powering ON / OFF

Turning the power ON

[1] Close the front cover.

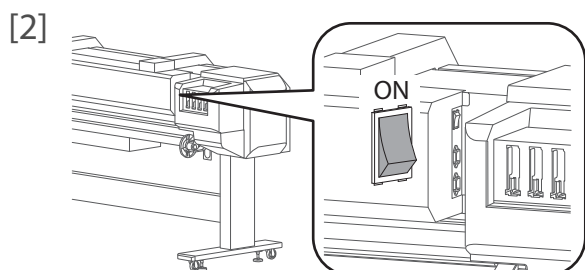

Turn ON the power switch of blower heater on the rear side of the printer.

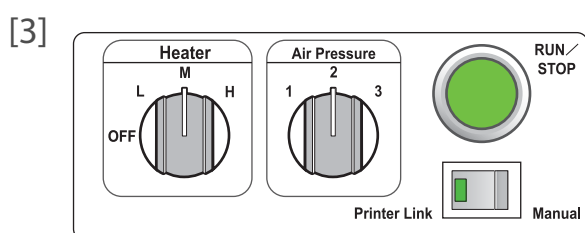

Turn Link switch of Blower heater on the front of the printer to "Printer Link".

- Link switch blinks.

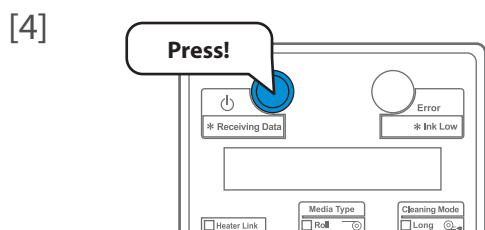

Press the power button to turn the power ON.

- The blue light becomes ON.
- This product starts its initialization operations.

Turning the power OFF

Important!

Use the printer with its power turned permanently on. When you are not using the printer, always leave the power on and put the printer into the sleep mode while not in use. If you do not put the printer into the sleep mode, the ink inside the printer could settle out and/or coagulate, causing poor image quality or printer failure.

👉 ["Sleep Mode" P. 31](#)

If the printer is going to be in Sleep mode for more than 2 weeks, perform "Long storage", and then turn the power OFF.

👉 ["Long Storage and Initial Charge" P. 131](#)

[1] Check that the printer completes printing and no media is loaded.

[2] Prepare items required for daily maintenance.

👉 ["Preparing for Daily Maintenance" P. 109](#)

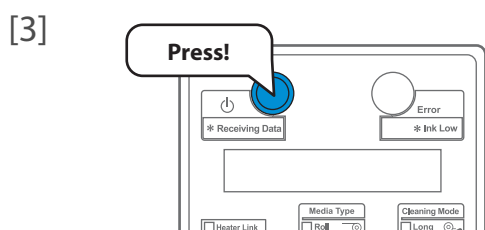

Press the power button to turn the power OFF.

- This product starts its powering off operations.
- The blue light becomes OFF.

[4]

Daily Maint. :	Start
----------------	-------

Press the [Enter] key.

[5]

Wash Exe ? :	Yes
--------------	-----

When using 4-color set, select whether or not to clean the cleaning wiper and flushing box with the cleaner.

Wash Exe ? :	No
--------------	----

- "Wash Exe? No": Cleaning is not performed automatically.
- "Wash Exe? Yes": Cleaning is performed automatically.

 **Note**

Note that the ink inside Print head is discharged by the cleaner; therefore some ink will be used.

[6]

Cleaning	** %
----------	------

The printer automatically performs the "Short" cleaning.

Wait for a while

- The carriage and cleaning wiper move to gain access to daily maintenance.

[7]

Daily Maint. :	End
----------------	-----

The message on the left will appear.

- You can start daily maintenance.

 ["Performing Daily Maintenance" P. 111](#)

- After the daily maintenance is complete, press the [Enter] key.

Power Off Printer

The printer will start turning off.

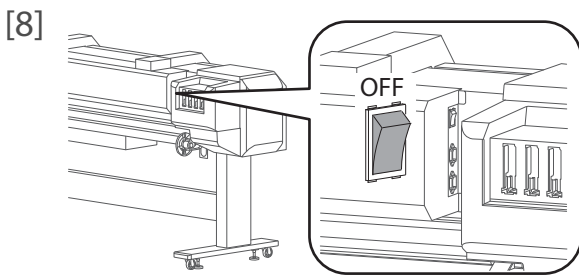

Turn OFF the power switch of Blower heater.

Sleep Mode

When you are not using the printer, always leave the power on and put the printer into the sleep mode while not in use. If you do not put the printer into the sleep mode, the ink inside the printer could settle out and/or coagulate, causing poor image quality or printer failure.

Make sure to follow the instructions on the operation panel to perform daily maintenance.

The following operations are performed during sleep mode.

- Ink circulation (every 24 hours).
- "Little Charge" (once a week).

Important!

- **Do not leave the printer in Sleep mode for more than 2 weeks.**
If the printer is going to be in Sleep mode for more than 2 weeks, perform "Long storage", and then turn the power OFF.
☞ ["Long Storage and Initial Charge" P. 131](#)
- **If the printer is going to be in Sleep mode for more than 1 week, follow the steps below to perform daily maintenance once a week.**
 - **Invert the ink cartridges back and forth to agitate ink.**
☞ ["Agitating ink" P. 99](#)
 - **Wake the printer from sleep mode (The printer will automatically perform "Little Charge").**
 - **Perform a nozzle check to see if there are no nozzle missing.**
 - **Perform daily maintenance, and put the printer into sleep mode.**

Starting Sleep Mode

Steps

- [1] Make sure that the printer's operating condition is as follows:
 - The front cover and the maintenance cover are closed.
 - No media is loaded.
 - The remaining ink level is sufficient.
 - The waste ink tank has enough space.

Important!

If you are going to use the sleep mode for a prolonged period of time, first empty the waste ink tank.

- [2] Prepare items required for daily maintenance.
☞ ["Preparing for Daily Maintenance" P. 109](#)

- [3] Press the [Menu] key.

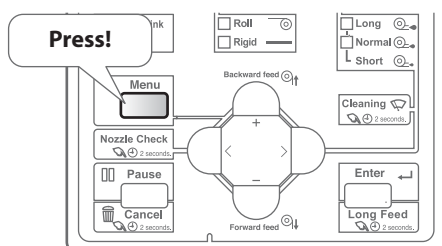

[4]

Menu1:	Sleep Mode >
---------------	------------------------

Press the [>] key.

[5]

SleepMode:	Start
-------------------	--------------

Press the [Enter] key.

[6]

Start Sleep Mode?

Press the [Enter] key.

[7]

Daily Maint. :	Start
-----------------------	--------------

Press the [Enter] key.

[8]

Wash Exe ? :	Yes
---------------------	------------

When using 4-color set, select whether or not to clean the cleaning wiper and flushing box with the cleaner.

Wash Exe ? :	No
---------------------	-----------

- "Wash Exe? No": Cleaning is not performed automatically.
- "Wash Exe? Yes": Cleaning is performed automatically.

 **Note**

Note that the ink inside Print head is discharged by the cleaner; therefore some ink will be used.

[9]

Cleaning	** %
-----------------	-------------

The printer automatically performs the "Short" cleaning.

Wait for a while

- The table, carriage and cleaning wiper move to gain access to daily maintenance.

[10]

Daily Maint. :	End
-----------------------	------------

The message on the left will appear.

- You can start daily maintenance.
 ["Performing Daily Maintenance" P. 111](#)

- After the daily maintenance is complete, press the [Enter] key.

Restart	- >	Enter
----------------	---------------	--------------

The sleep mode will start.

- To exit the sleep mode, press the [Enter] key.

 **Note**

- The power button flashes in blue while the printer is in the sleep mode.
- It may take some time for Blower heater to stop because it has to cool down.
- Stop Blower heater manually in Manual mode.
- Depending on the time elapsed since the last automatic cleaning, the printer may perform an automatic head cleaning or ink charging when powered on or waking up from sleep mode. Such operation does not depend on the sleep mode settings. It is an automatic maintenance function of the printer.

 Important!

The following message appears on the operation panel when the printer has been in sleep mode for one week.

- "Perform Nzl Chk -> E"

Follow the steps below to run a nozzle check and ensure that all nozzles are firing properly.

- Press the [Enter] key to wake up from sleep mode.
- Follow the instructions on the operation panel to invert the ink bag back and forth to agitate ink.
- Load a media to print a nozzle check pattern and perform a nozzle check.

 ["Nozzle check" P. 43](#)

- If nozzle missing is found on the nozzle check print, perform the head cleaning.

 ["Cleaning" P. 45](#)

Then, put the printer into sleep mode again.

Loading the media

Loading a roll media in the printer



Depending on the type of the media, we recommend that two or more persons set the media.

1. Loading Roll Media onto the Roll media holder

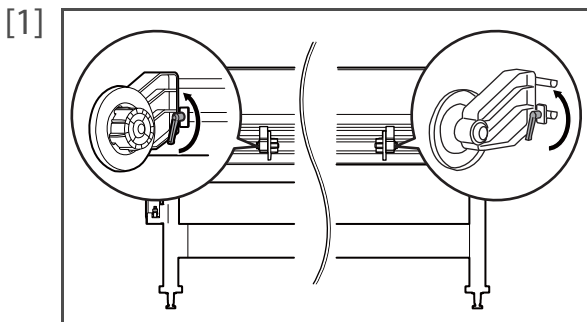

Loosen Fixing levers on the Roll media holders (both left and right) on the back of the printer.

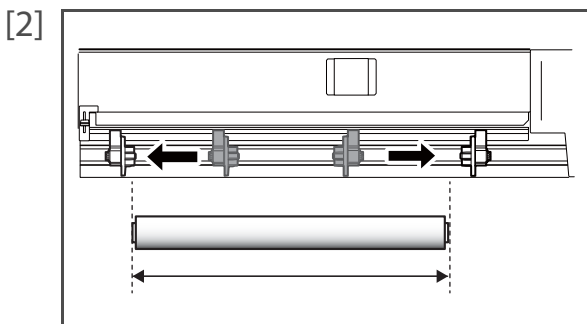

Set the distance between Roll media holders wider than the actual width of the roll media to be set.

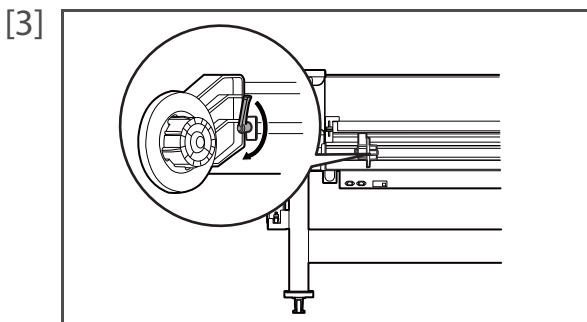

Tighten Fixing lever of Roll media holder (left) and fix the Roll media holder (left).

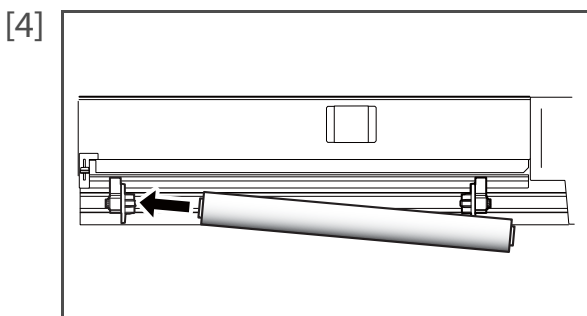

Set the roll media to Roll media holder (left).

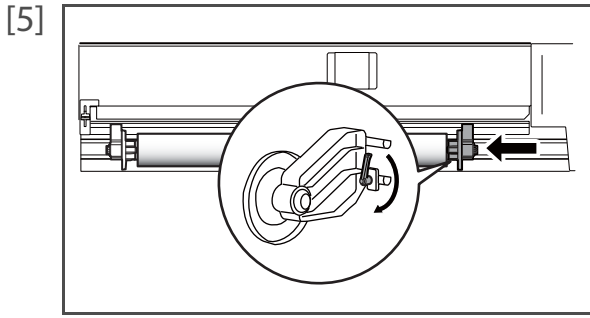

[5] Attach Roll media holder (right) to the roll media and tighten Fixing lever.

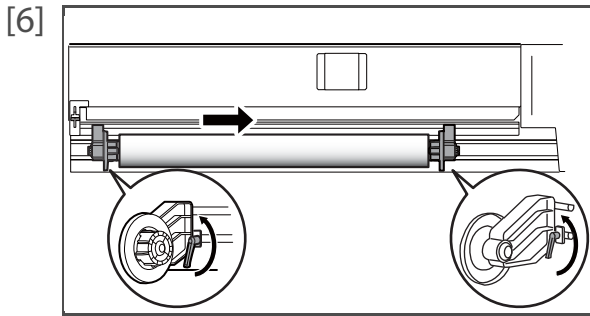

[6] Loosen the Fixing levers of the right and left Roll media holders, move the roll media to the center.

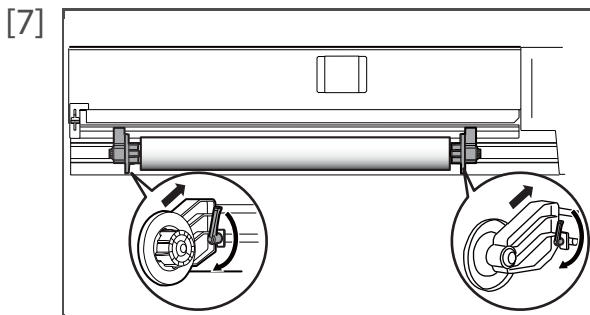

[7] Press Roll media holder toward the printer and fix the Fixing levers.

Note

When tightening Fixing lever, press Roll media holder toward the printer.

If you do not press Roll media holder, Fixing lever may not be completely locked because of the weight of the roll media.

2. Loading Roll Media into the printer

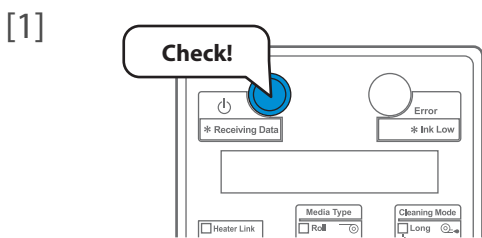

[1] Make sure that the printer is turned ON.

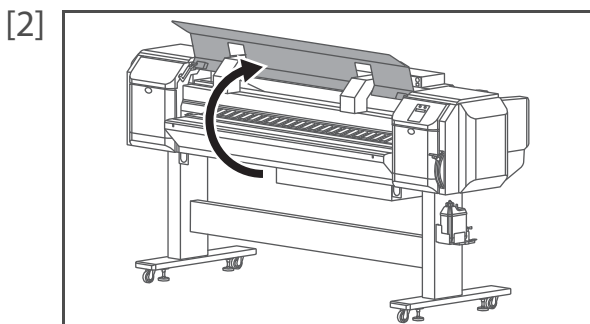

[2] Open the front cover.

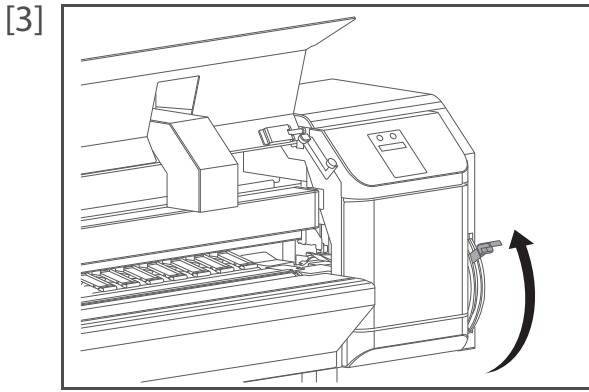

Raise the media loading lever.

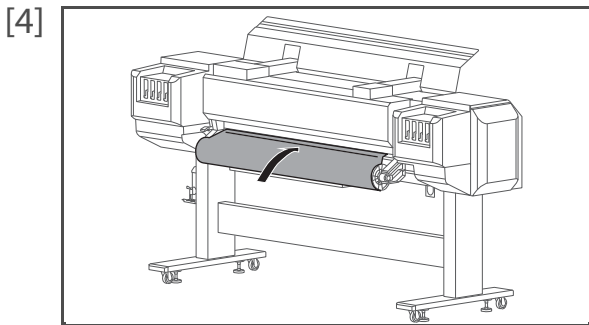

Load the roll media to Media feed slot.



Note

If the end of the roll media is not wound tightly, wind it tightly again, and then load it.

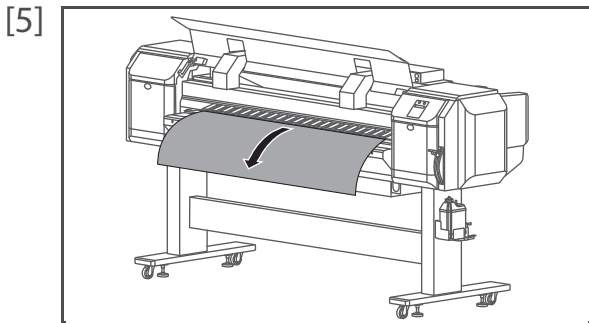

Pull the roll media out about 1 m from the front Media feed slot.

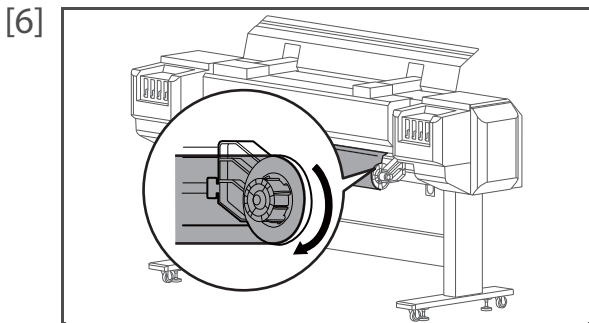

Rewind the roll media a little by rolling Flange on Roll media holder while holding the edge of the media, and eliminate any slack or slant.



Note

If you set the roll media free while rewinding, the roll media may fall out from Media feed slot and fall toward the back of the printer.

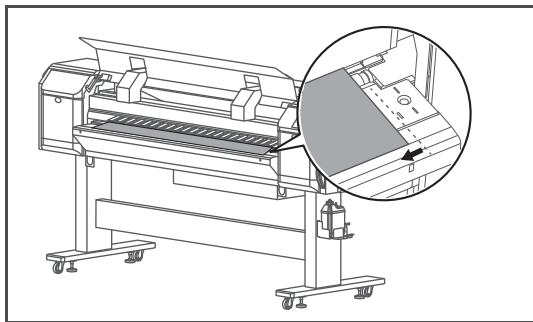

Confirm that the right edge of the roll media does not go beyond the loading mark. If it does, it may affect print quality.

3. After loading the media...

[1] **Lever Up** "Lever Up" is displayed on the Operation panel.

[2] Lower the media loading lever.

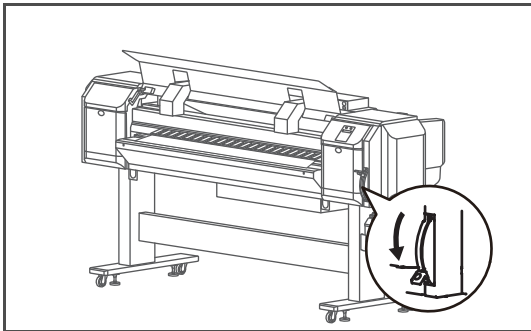

[3] Make sure that the edges of the media is appropriately pressed by Pressurizing rollers.

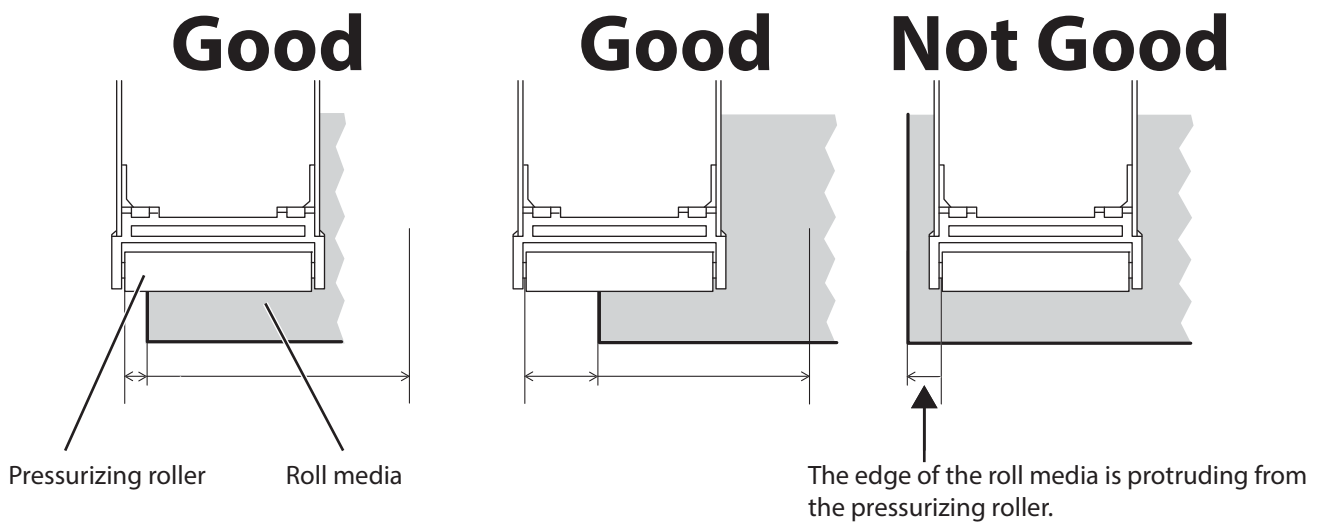

[4] When the media is not appropriately pressed by Pressurizing rollers, follow the procedure to adjust the position of the roll media.

- Raise the media loading lever.
- Loosen Fixing levers of the right and left Roll media holders, and move the roll media to left or right.
- Press Roll media holder toward the printer and fix the Fixing levers.

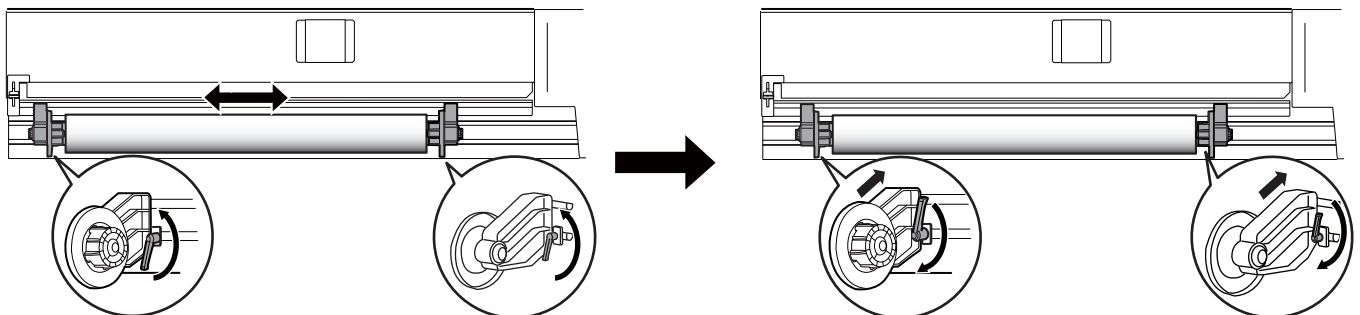

Note

- If the media is not appropriately pressed by Pressurizing rollers, the media may be misaligned or creased during printing.
- When tightening Fixing lever, press Roll media holder toward the printer.
If you do not press Roll media holder, Fixing lever may not be completely locked because of the weight of the roll media.

[5]

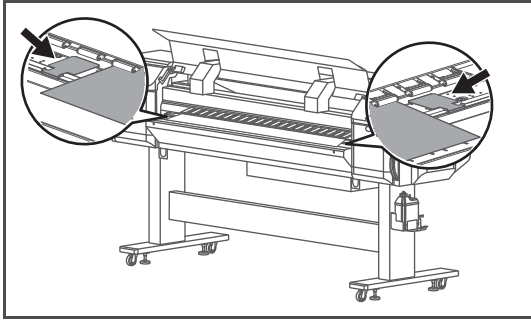

Set the media holder at both edges of the media.

Important!

With the default settings, the printing operation starts 5 mm from the edge of the media. To hold down the media, make sure that the part overlapping the media is less than 5 mm in length.

[6]

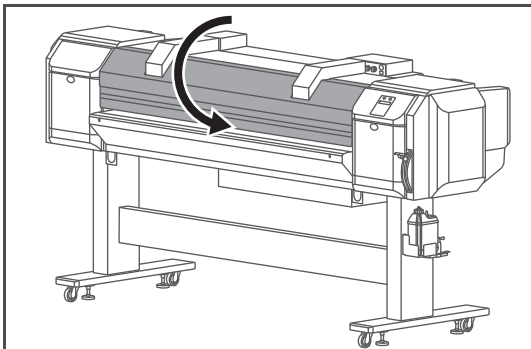

Close the front cover.

[7]



"Media: Type ** OK?" is displayed on the Operation panel.

- Press the [+] key or [-] key on Operation panel to select the User Type Setting.
- Check that the media type in the selected user type is set to "Roll".

["**>10: Rigid / Roll" P. 74](#)

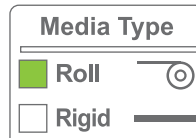

[8]

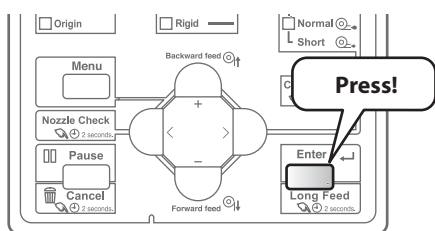

Press the [Enter] key to execute media initialization.

- That ends the media loading procedure.

Loading a rigid media in the printer

Important!

Depending on the type of the media, we recommend that two or more persons set the media.

1. Loading Rigid Media into the printer

[1]

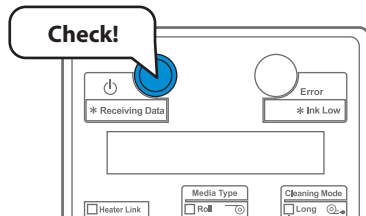

Make sure that the printer is turned ON.

[2]

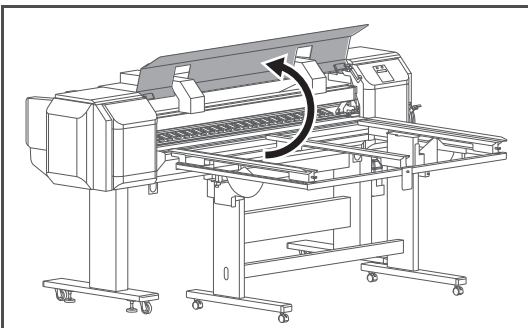

Open the front cover.

Note

Before installing the media-feed table, always open the front cover. If the cover is closed, the printer may not work properly.

[3]

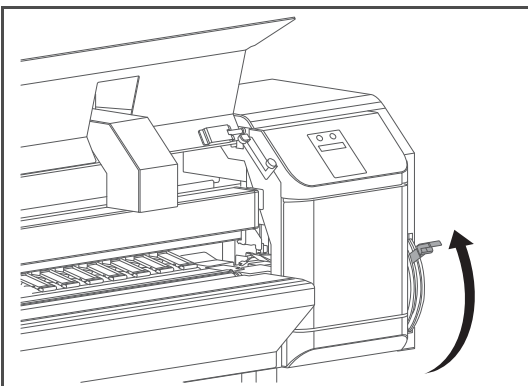

Raise the media loading lever.

Note

Media-feed table is excluded from the illustration for simplicity.

[4] Loosen the rail retaining screw on Media-feed table (rear side), and widen the rails to the sides so that you can place the rigid media.

Make sure that the rigid media is set on the center of the printer.

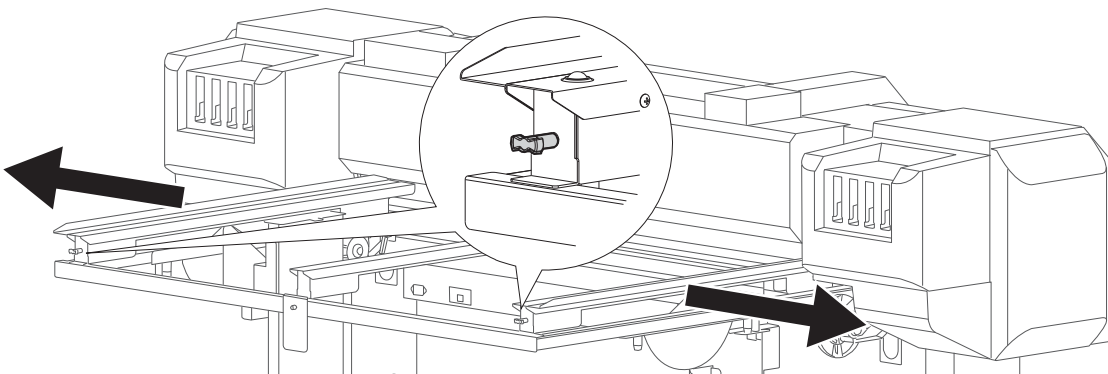

- [5] Place the rigid media on the rails and tighten the rail retaining screw at where there is a 5 mm gap between the stoppers on both sides and the media.

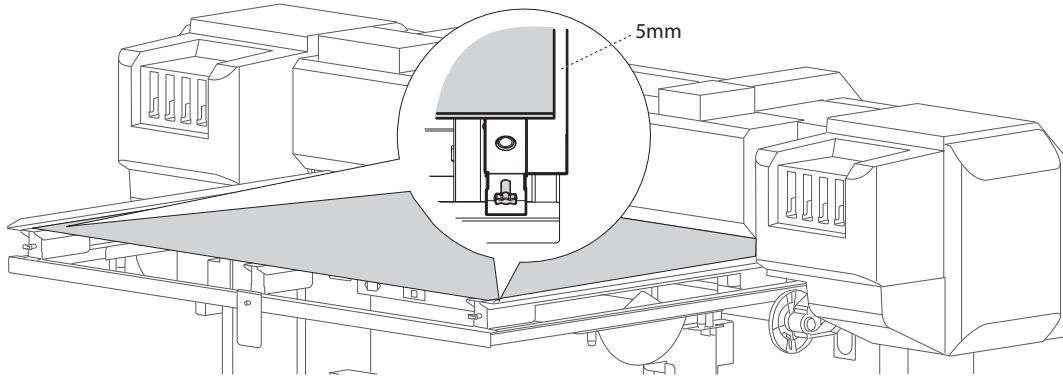

- [6] Place the rigid media on Media-feed table (front side) in the same way, and fix the rails at where there is a 5 mm gap between the stoppers on both sides and the media.

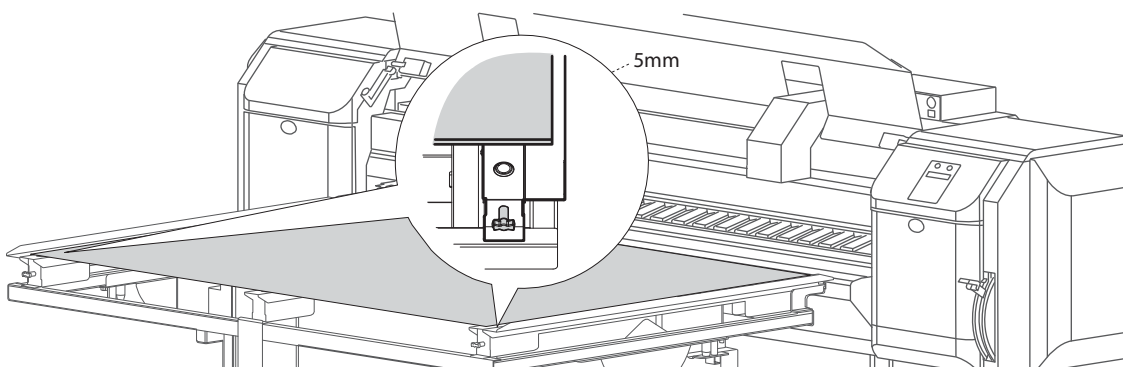

- [7] From the rear side of the printer, insert the rigid media into Media feed slot.

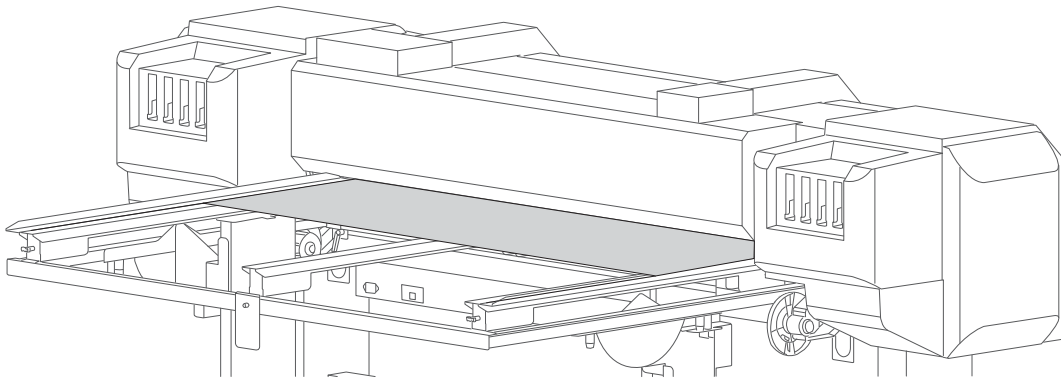

- [8] If the right edge of the roll media goes further right from the loading mark when seen from the front, adjust the position of Media-feed table's rails.

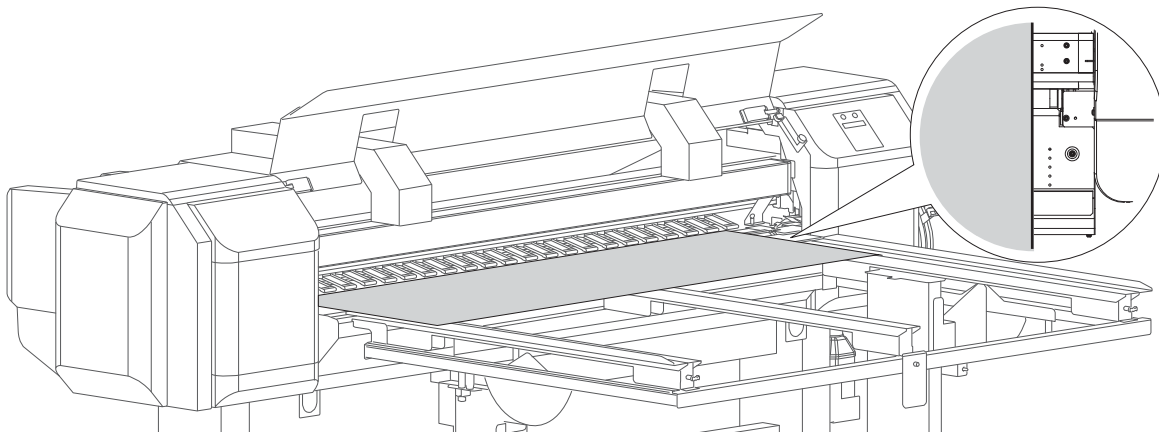

2. After loading the media...

[1] **Lever Up**

"Lever Up" is displayed on the Operation panel.

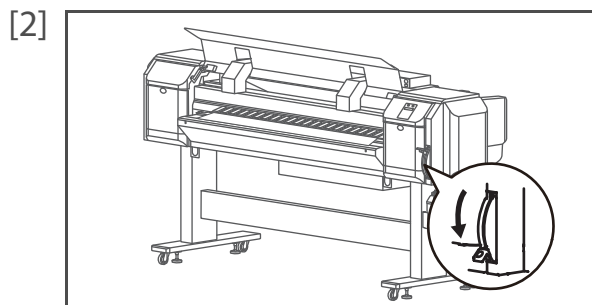

Lower the media loading lever.

Note

Media-feed table is excluded from the illustration for simplicity.

[3] Make sure that the edges of the media is appropriately pressed by Pressurizing rollers. More than 50% area of the pressurizing roller on the far left and right should hold down the edge of the media. If not, adjust position of the rail on the media-feed table.

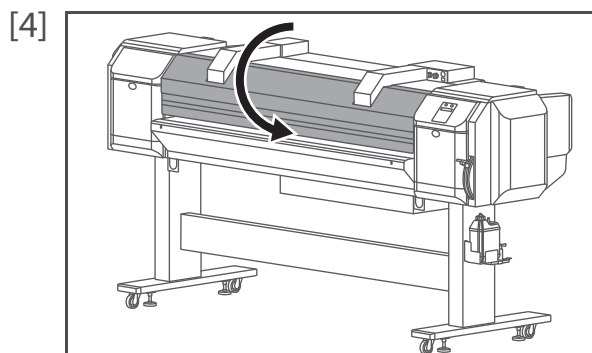
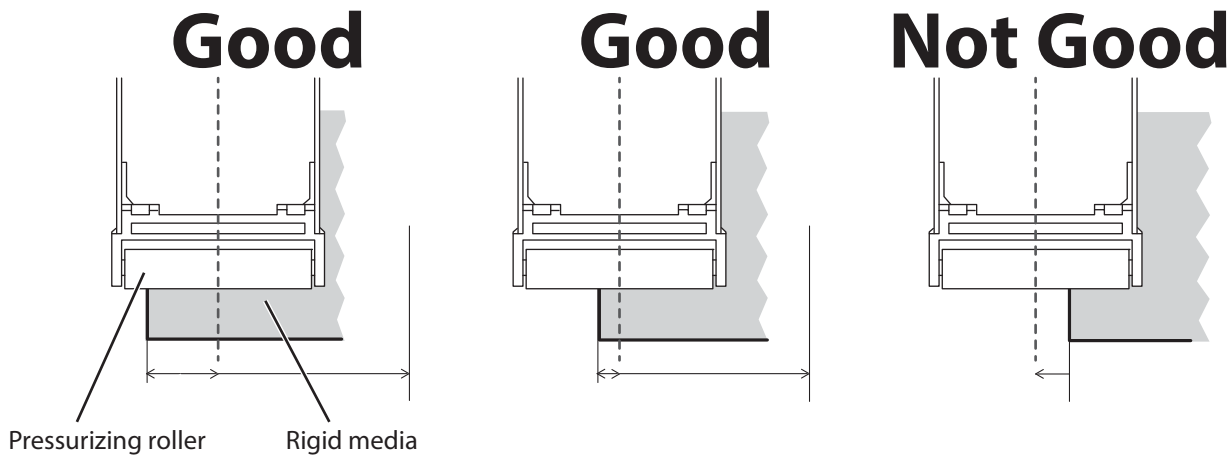

Close the front cover.

Note

Media-feed table is excluded from the illustration for simplicity.

[5] **Media : Type ** OK?**

"Media: Type ** OK?" is displayed on the Operation panel.

- Press the [+] key or [-] key on Operation panel to select the User Type Setting.
- Check that the media type in the selected user type is set to "Rigid".

****>10: Rigid / Roll" P. 74**

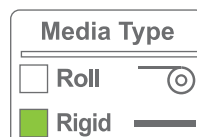

 **Note**

If the media type is not set to "Rigid", go to "Menu 2: User Type >" - "User: Type*" - "***> 10: Rigid / Roll" and select "Rigid".

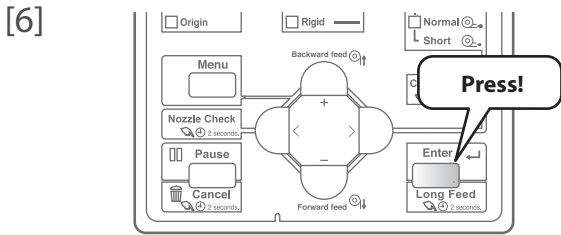

Press the [Enter] key to execute media initialization.
• That ends the media loading procedure.

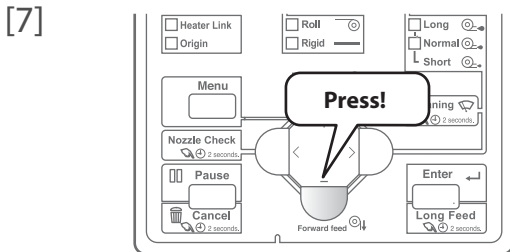

Press down the [-] key on Operation panel for a while, and check that the rigid media can be fed no problem.

[8] When feeding does not go smoothly, turn the screws of the front and back casters of Media-feed table (4 places each) with a spanner and raise the height slowly to adjust the position for smoother feeding.

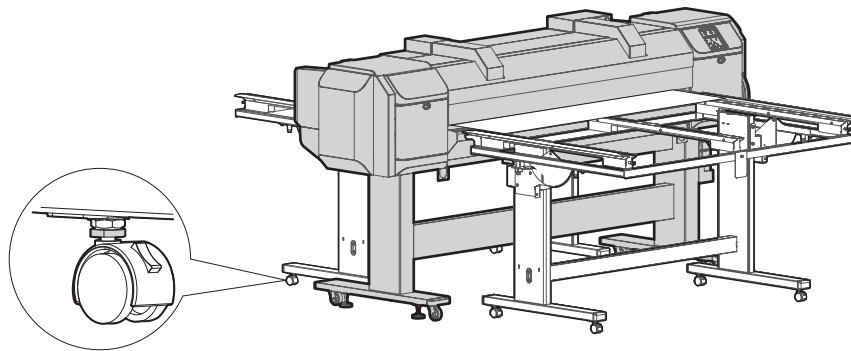

[9] Use a spanner and tighten the hexagon nuts of the caster's height adjuster (4 places) toward the Media-feed table side.
• The height of the caster is fixed.

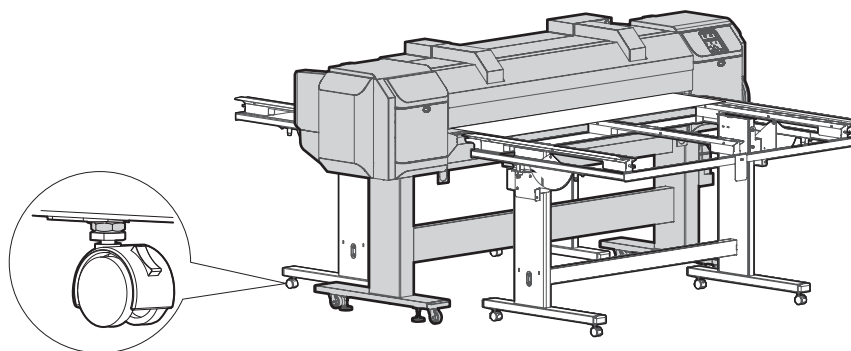

Nozzle check and cleaning

Before starting everyday operation, please perform nozzle check printing to check the print head condition. If nozzle clog is found, perform cleaning.

This printer offers the following two kinds of nozzle checks:

- Nozzle Check - Prints the nozzle check patterns.
- Nozzle Check B - Prints the nozzle check patterns on the partially colored background.

Note

- "Nozzle Check B" will only appear in the menu if the printer is set to 5-color configuration.
- When using white ink, colored media, transparent films or semi-transparent films (such as OHP film, tracing paper and more) are recommended to use for nozzle check.

Nozzle check

Nozzle check steps

- [1] Load the media for Nozzle check.

 ["Loading the media" P. 34](#)

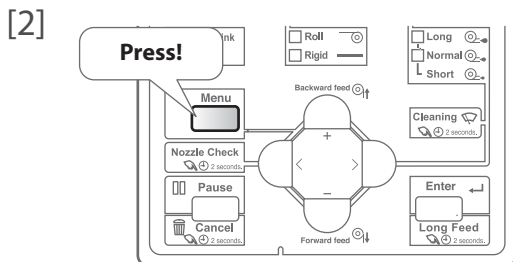

Press the [Menu] key.

- [3] **Menu 4 :** **Test Print >**

Press the [-] key several times, to bring up the display on the left.

- Press the [>] key.

- [4] **Test1:** **Nozzle Check**

Press the [Enter] key.

- To select Nozzle Check B, press the [-] key to display "Nozzle Check B", then press the [Enter] key.

- Test2:** **Nozzle Check B**
- Nozzle check patterns will be printed.

[5] Check the print result.

- If there is nozzle missing, go to "[Cleaning steps](#)" P. 45.
- If all lines are clearly printed, you can start printing.
- The figure below are examples of the 4-color setting Nozzle Check patterns.

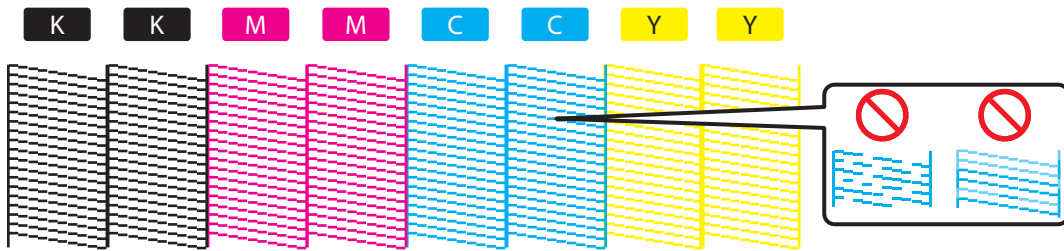

- Nozzle Check B is printed on the partially colored background.
- The figure below is an example of the Nozzle Check B pattern. In this example, non-colored background area is shown in gray.

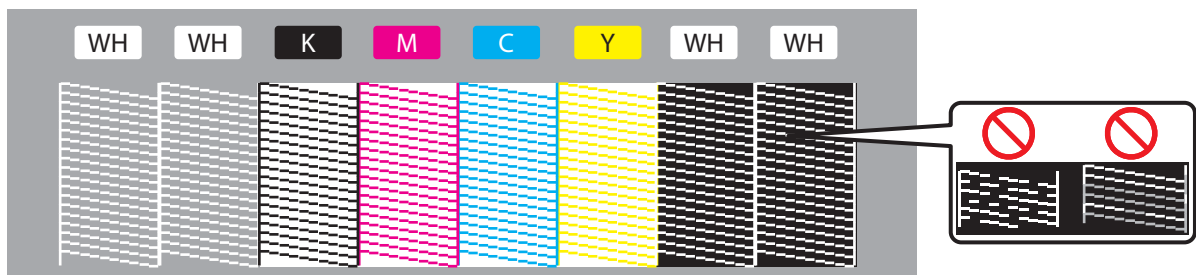

 Note

The printer information (date and time of printing, printer's serial number, firmware version) is printed on the nozzle check pattern.

Cleaning steps

- [1] Press the [Cleaning] key, so that the “Normal” indicator (one of the “Cleaning Mode” indicators) lights steady.
- The cleaning mode will be set to “Normal”.

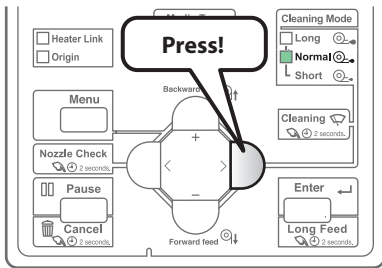

- [2] Press the [Cleaning] key for more than two seconds.
- Cleaning will start.

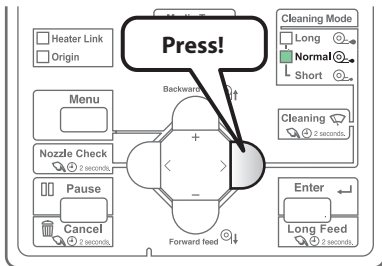

- [3] Conduct a nozzle check, again.

 ["Nozzle check steps" P. 43](#)

- If there is still nozzle missing, repeat normal cleaning.
See ["Head cleaning" P. 120](#) regarding “Short”, “Long”, “Little Charge” and “Initial Charge” cleaning.

Setting the Printing Precision

Before starting to print for the first time, adjust the printing precision.

Print quality adjustment

It is used for optimizing the quality of image prints.

Adjustment methods for this printer are as follows.

Adj. Print 1:	Standard
----------------------	-----------------

Adjusts only the print mode used by the current user definition.

When you have adjusted the print mode using Standard, make the resolution, pass count, and print direction of the print mode on the RIP side equal to those of the userdefined print mode.

Adj. Print 2:	Custom
----------------------	---------------

Allows you to adjust also a print mode other than the print mode used by the current user definition.

This method optimizes print quality even if the print mode on the RIP side is different from the user-defined mode.



Note

- When newly setting or changing the user type setting after adjusting Standard adjust print, make sure to adjust print.
- When you change the print mode after performing the Standard adjustment, make sure to perform the Standard adjust print for the selected print mode.
- The Custom adjust print can adjust the print quality for all print modes at once. If you have already performed the Custom adjustment, there is no need to perform it again even if you change the print mode.
- When specifying a print mode for RIP software, etc, that is different from the mode set in the usertype setting, perform Custom print quality adjustment and check all patterns (A to F), and then adjust any patterns that are misaligned beforehand.

Print quality adjustment steps

[1] Load the media.

 ["Loading the media" P. 34](#)

[2]

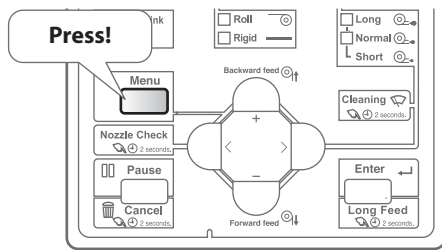

Press the [Menu] key.

[3]

Menu 1: Sleep Mode >

Press the [-] key.

[4]

Menu 2: User Type >

Press the [>] key.

[5]

User : Type 1

Use the [+] / [-] key to select a user type.

- Press the [Enter] key.

[6]

*** * > 2: Adjust Print >**

Press the [-] key several times, to bring up the display on the left.

- Press the [>] key.

[7]

Adj. Print 1 : Standard

Select the adjustment method with the [+] / [-] key.

- Press the [Enter] key.

Adj. Print 2 : Custom

Note

- In Standard print quality adjustment and Custom print quality adjustment, the names in the available patterns are different. For details, refer to the page below.

 ["Adj. Print 1: Standard" P. 64](#)

 ["Adj. Print 2: Custom" P. 65](#)

- For a pre-adjustment check, select "Confirm Ptn."

Check the printing results in "Confirm Ptn.,"

- To adjust large misalignment, select "Rough Pattern".
- To adjust small misalignment, select "Fine Pattern".

[8] Follow the steps below and adjust the print quality.

 ["Steps" P. 66](#)

Media feed adjustment

This adjustment is necessary when:

- you use this product for the first time.
- you change the type of the media.

In other cases, proceed to ["Nozzle check" P. 43](#).

For this adjustment, you need a ruler. Use a commercially available ruler.



Note

If you encounter any of the following problems with the printing results, you may be able to solve them by adjusting the media feed.

- Printed images overlap.
- White lines are printed over images.

Media feed adjustment steps

[1] Load the media.

["Loading the media" P. 34](#)

[2]

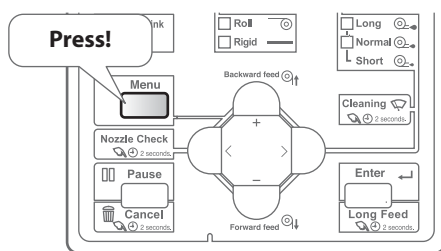

Press the [Menu] key.

[3]

Menu 1: Sleep Mode >

Press the [-] key.

[4]

Menu 2: User Type >

Press the [>] key.

[5]

User : Type 1

Use the [+] / [-] keys to select a user type.

- Press the [Enter] key.

[6]

*** * > 3: PF Adjust >**

Press the [-] key several times, to bring up the display on the left.

- Press the [>] key.

[7]

PF 1 : Initial Print

Use the [+] / [-] key to select a menu.

PF 2 : Initial Change

- Press the [Enter] key.

PF 3 : Confirm Print

- Follow the steps below and adjust the print quality.

PF 4 : Micro Print

["Steps" P. 68](#)

PF 5 : Micro Change

Operating from Operation panel

Feeding and cutting media

- [1] Check that Media loading lever is lowered.

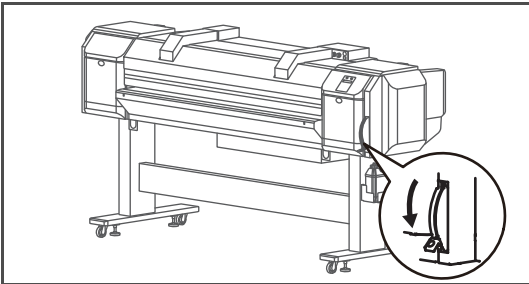

- [2] Press the [Forward] key or the [Backward] key on Operation panel.
- [Forward] key: The media is fed forward.
 - [Backward] key: The media is fed backward.

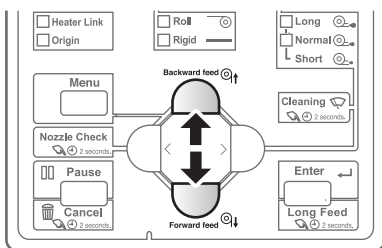

- [3] Release the [Forward] key or the [Backward] key on Operation panel after feeding the media to the desired position.

- [4] Open the front cover.

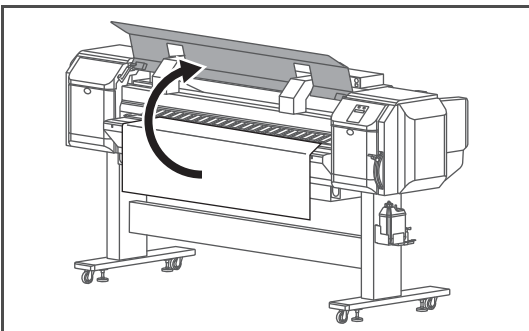

- [5] Place a razor blade on the media cut groove on the media guide, and cut the roll media.

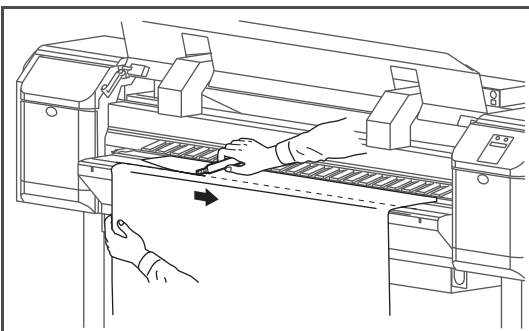

CAUTION



Pay attention to the following points when you cut roll media. Mishandling the razor blade may cause a cut on your finger or hand.

- When you hold media, do not place your finger on the media cut groove.
- Move the razor blade along the media cut groove.

Pausing / Restarting printing

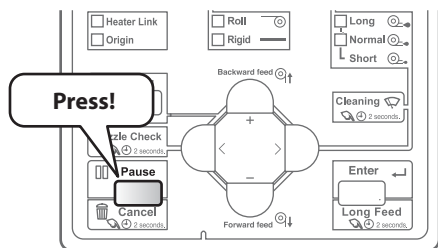

To halt printing, press the [Cancel] key.

- The printing pauses.
- To resume printing, press the [Enter] key.

Note

- In this operation, printing data sent to the product are not deleted.
- Please see the followings when canceling printing and deleting data.

["Canceling printing" P. 50](#)

Important!

Mutoh cannot guarantee the print quality when you resume the print.

Canceling printing

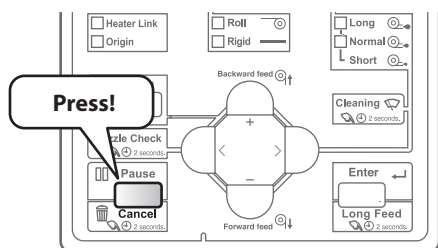

Press and hold the operation key on the operation panel for two seconds or more during printing.

- The printing is canceled (it cannot be restarted).
- The printing data sent to the product are deleted.

Note

You can alternatively do this via the printer driver or the MSM's remote panel.

Starting printing during warming up

Steps

- | | | |
|-----|-------------------------|--|
| [1] | Warming Up | Confirm that the printer is warming up. <ul style="list-style-type: none">• "Warming Up" is displayed on Operation panel. |
| [2] | Skip -> Enter | Print data will be sent. <ul style="list-style-type: none">• "Warming Up" and "Skip ->Enter" is displayed on Operation panel. |

CAUTION



While "Warming Up" is displayed, do not touch Media guide.

You could burn yourself.

- [3] Press the [Enter] key on the operation panel.
- The printer starts printing.

 Important!

If you start printing during warming up, print quality will not be guaranteed.

 Note

Even when you start printing during warming up, warming up continues until the temperature reaches the set temperature.

What you can do on the operation panel during printing

[1]  Press the [Menu] key while any of the messages on the left is displayed.





[2]  Press the [+] / [-] key to select a menu.

 ["Menu 1: PF Micro Adjustment" P. 51](#)

 ["Menu 2: Backup" P. 52](#)

 ["Menu 3: Job Status" P. 52](#)





Menu 1: PF Micro Adjustment

With this menu item, you can alter the micro-adjustment value for the feed correction. The alteration will be valid for the current printing only.

- See the following related sections of Panel Setting Menus:

 ["***>3: PF Adjust" P. 68](#)

[1]  Press the [Enter] key.



[2] 

- Use the [+] / [-] key to change the setting value.
- Press the [Enter] key to set the changed value.



 Note

- The changed value set with this menu item will become invalid when the printing ends.
- To have the change reflected in the currently selected User Type, save it using "Menu 5: Backup".

Menu 2: Backup

With this menu item, you can have a change that you made via “Menu1: PF Micro Adj.” reflected in the currently selected User Types.

- [1]

Menu 2 :	Backup
-----------------	---------------

 Press the [Enter] key.
- [2]

Update Parameter?

 Press the [Enter] key.
- | |
|-------------------------------|
| * Parameter Updating * |
|-------------------------------|

 The setting value will be saved.

Menu 3: Job Status

This menu item displays data on the job being printed.

- See the following related sections of Panel Setting Menus:
 ["Menu 10: Job Status" P. 96](#)

- [1]

Menu 3 :	Job Status
-----------------	-------------------

 Press the [Enter] key.
- [2]

ToDoLength :	XXX.Xm
---------------------	---------------

 Use the [+] / [-] key to select a menu item.
- | | |
|---------------|---------------|
| Done : | XXX.Xm |
|---------------|---------------|

 • ToDoLength: display this to check the total length (media feed direction) of the job being printed.
- | | |
|-----------------|---------------|
| Remain : | XXX.Xm |
|-----------------|---------------|

 • Done: display this to check how much of the current job has been printed.
- | | |
|----------------------|-------------|
| Remain Time : | Xmin |
|----------------------|-------------|

 • Remain: display this to check how much of the current job remains to be printed.
- Remain time: displays the time remaining to complete the print job.

Note

- The values displayed by this function are approximate. They are not guaranteed to be rigorously accurate.
- If the print job data contains no length information, “0” will be displayed for all these items.

Chapter 2 Advanced Operations



Introduction	55
Operating the keys to use the menus	55
Panel setup menu	56
Menu 1: Sleep Mode	60
Menu 2: User Type	61
Menu 3: Setup	75
Set 1: Spitting	75
Set 2: Side Margin	76
Set 3: Take-up	77
Set 4: Media Location	77
Set 5: Origin	78
Set 6: Standby Heating	79
Set 7: Head Travel	79
Set 8: Multi Strike	79
Set 9: Slant Check	79
Set 10: Auto Cleaning	80
Set 11: Roll Length	82
Set 12: FrontInterlace	83
Set 13: BtmInterlace	83
Set 14: Ink Status	84
Set 15: Life Times	84
Set 16: Header Dump	85
Set 17: Start Feed	85
Set 18: Obstacle Check	86
Set 19: Initialization	86
Set 20: Temporary	86
Menu 4: Test Print	87
Test 1: Nozzle Check	87
Test 2: Nozzle Check B	87
Test 3: Mode Print	88
Test 4: Setup List	88
Test 5: Palette	89
Menu 5: Cleaning	89
Menu 6: Menu Option	90

Menu 7: Maintenance	91
Maintenance 1: Daily Maintenance	91
Maintenance 2: Long Storage	91
Maintenance 3: Cap Out	92
Maintenance 4: Longstore	92
Maintenance 5: Ink Replace	92
Maintenance 6: Wash Replace	92
Maintenance 7: Color Maintenance	93
Menu 8: Version	93
Menu 9: Initial	94
Initial 1: Language	94
Initial 2: Length	94
Initial 3: IP Address	94
Initial 4: Subnet Mask	95
Initial 5: Gateway	95
Initial 6: Alert Buzzer	95
Menu 10: Job Status	96

Introduction

Using the panel setting menus, configure various kinds of settings for the printer.

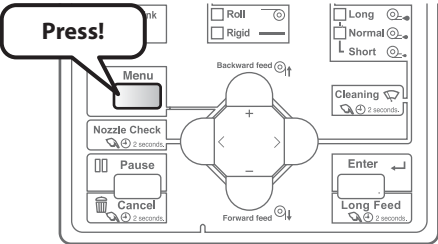
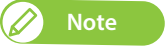
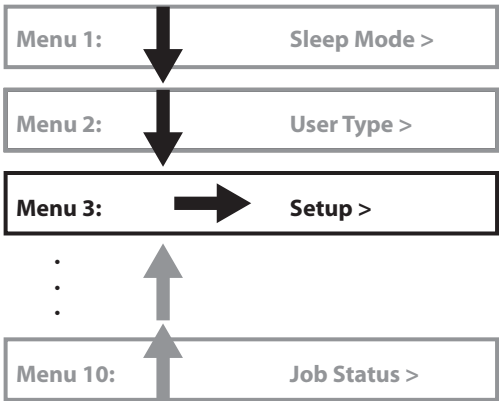
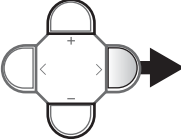
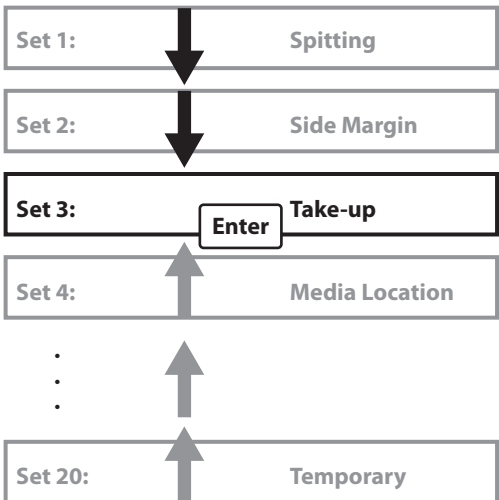
Operating the keys to use the menus

- [1]  To access the panel setting menus, press the [Menu] key.
-  **Note**
You cannot access the panel setting menus while printing or receiving data (the power button is flashing).
- [2]  Use the [+] / [-] key to scroll through the menus.
- Press the [>] key to access the menu you are on.
- 
- [3]  Use the [+] / [-] key to select submenus, enter numeric values and so forth.
- Press the [Enter] key to set/execute.
- 
- Use the [Cancel] key to return to the menu/submenu.
(In the case shown on the left, pressing [Cancel] key will return to "Menu 3: Setup>")
- 

Panel setup menu

Menu 1: Sleep Mode

Menu 1: Sleep Mode >

Activate Sleep Mode.

Submenus

Sleep Mode : Start

 [Menu 1: Sleep Mode](#)

Menu 2: User Type

Menu 2: User Type

Making media settings.

Submenus

**> 1: Print Mode

 [**> 1: Print Mode](#)

**> 2: Adjust Print >

 [**> 2: Adjust Print >](#)

**> 3: PF Adjust >

 [**> 3: PF Adjust](#)

**> 4: Vacuum Fan

 [**> 4: Vacuum Fan](#)

**> 5: Thickness

 [**> 5: Thickness](#)

**> 6: Thickness Adj.

 [**> 6: Thickness Adj.](#)

**> 7: Media Initial

 [**> 7: Media Initial](#)

**> 8: Media Width

 [**> 8: Media Width](#)

**> 9: Pass Wait

 [**> 9: Pass Wait](#)

**> 10: Rigid / Roll

 [**> 10: Rigid / Roll](#)

**> 11: Initial

 [**> 11: Initial](#)

Menu 3: Setup

Menu 3: Setup >

Various settings of the printer are configured.

Submenus

Set 1: Spitting

 [Set 1: Spitting](#)

Set 2: Side Margin

 [Set 2: Side Margin](#)

Set 3: Take-up

 [Set 3: Take-up](#)

Set 4: Media Location

 [Set 4: Media Location](#)





Set 5:	Origin	 Set 5: Origin
Set 6:	StandbyHeating	 Set 6: Standby Heating
Set 7:	Head Travel	 Set 7: Head Travel
Set 8:	Multi Strike	 Set 8: Multi Strike
Set 9:	Slant Check	 Set 9: Slant Check
Set 10:	Auto Cleaning	 Set 10: Auto Cleaning
Set 11:	Roll Length	 Set 11: Roll Length
Set 12:	FrontInterlace	 Set 12: FrontInterlace
Set 13:	BtmInterlace	 Set 13: BtmInterlace
Set 14:	Ink Status	 Set 14: Ink Status
Set 15:	Life Times	 Set 15: Life Times
Set 16:	Header Dump	 Set 16: Header Dump
Set 17:	Start Feed	 Set 17: Start Feed
Set 18:	Obstacle Check	 Set 18: Obstacle Check
Set 19:	Initialization	 Set 19: Initialization
Set 20:	Temporary	 Set 20: Temporary

Menu 4: Test Print

Menu 4:	Test Print >
---------	--------------

Performs nozzle check of the print head and setup list.

Submenus

Test 1:	Nozzle Check	 Test 1: Nozzle Check
Test 2:	Nozzle Check B	 Test 2: Nozzle Check B
Test 3:	Mode Print	 Test 3: Mode Print
Test 4:	Setup List	 Test 4: Setup List
Test 5:	Palette	 Test 5: Palette



Note

“Nozzle Check B” will only appear in the menu if the printer is set to 5-color configuration.

Menu 5: Cleaning

Menu 5: **Cleaning >**

Cleans the print head and performs the initial ink charging.

Submenus

Time : **Short**

 [Menu 5: Cleaning](#)

Time : **Normal**

Time : **Long**

Time : **Little Charge**

Time : **Initial Charge**

Menu 6: Menu Option

Menu 6: **Menu Option >**

Choose whether to display the menus in "Menu 3: Setup".

 [Menu 6: Menu Option](#)

Menu 7: Maintenance

Menu 7: **Maintenance >**

Configures the periodical printer maintenance.

Submenus

Mnt. 1: **Daily Maintenance**

 [Maintenance 1: Daily Maintenance](#)

Mnt. 2: **Long Storage**

 [Maintenance 2: Long Storage](#)

Mnt. 3: **Cap Out**

 [Maintenance 3: Cap Out](#)

Mnt. 4: **Longstore**

 [Maintenance 4: Longstore](#)

Mnt. 5: **Ink Replace**

 [Maintenance 5: Ink Replace](#)

Mnt. 6: **Wash Replace**

 [Maintenance 6: Wash Replace](#)

Mnt. 7: **Color Mainte.**

 [Maintenance 7: Color Maintenance](#)

Menu 8: Version

Menu 8: **Version >**

Displays the versions of the firmware.







 [Menu 8: Version](#)

Menu 9: Initial

Menu 9: Initial >

Sets the interface language and units, to set up the network, or to configure the menu display settings.

Submenus

Initial 1: Language	 Initial 1: Language
Initial 2: Length	 Initial 2: Length
Initial 3: IP Address	 Initial 3: IP Address
Initial 4: Subnet Mask	 Initial 4: Subnet Mask
Initial 5: Gateway	 Initial 5: Gateway
Initial 6: Alert Buzzer	 Initial 6: Alert Buzzer

Menu 10: Job Status

Menu 10: Job Status >

Displays various information of previous print.

 [Menu 10: Job Status](#)

Menu 1: Sleep Mode

Menu 1: Sleep Mode >

Activate Sleep Mode.

Make sure to follow the instructions on the operation panel to perform daily maintenance.

 ["Sleep Mode" P. 31](#)

Submenu

Sleep Mode 1 : Start

Press the [Enter] key to start Sleep Mode.

Important!

During Sleep Mode, even if the set amount of time has passed, Head cleaning is not performed under the following circumstances.

- When the front cover is open.
- When the maintenance cover is open.
- The waste fluid tank is full.
- High capacity ink pack adapters have been removed.
- The inserted S/C card is not the genuine S/C card, etc.

If one of the above conditions occurs during Head cleaning, cleaning is stopped.

When the printer returns to a normal state, Head cleaning is restarted.

Menu 2: User Type

Menu 2: User Type >

You can have up to 30 groups of User Type, labeled "Type1" to "Type30". When you select a User Type group ("Type") and press the [Enter] key, that definition group will be set for the printer. Also, a submenu will be displayed.

Setting values

User: Type 1

Select a "Type" number, from "Type1" to "Type30".

Important!

When you change to another User Type, all the settings that can be set via the User Type will be changed. When using the printer for the first time or when changing the media, configure the items for the User Type.

User: Type 1

Making media settings.

Submenus

**> 1: Print Mode

 ****>1: Print Mode**

**> 2: Adjust Print >

 ****>2: Adjust Print>**

**> 3: PF Adjust >

 ****>3: PF Adjust**

**> 4: Vacuum Fan

 ****>4: Vacuum Fan**

**> 5: Thickness

 ****>5: Thickness**

**> 6: Thickness Adj.

 ****>6: Thickness Adj.**

**> 7: Media Initial

 ****>7: Media Initial**

**> 8: Media Width

 ****>8: Media Width**

**> 9: Pass Wait

 ****>9: Pass Wait**

**> 10: Rigid / Roll

 ****>10: Rigid / Roll**

**> 11: Initial

 ****>11: Initial**

**>1: Print Mode

****> 1: Print Mode**

Making settings for print mode.

- Pressing the [>] key while a mode is displayed will bring up detailed information on that mode (resolution, number of passes, print direction), which will be displayed for as long as the key is held down.
- After setting the print mode, go on to setting of effect.

Setting values

Mode : Quality X ->	Sets up to perform high quality printing. There are four patterns: Quality 1 to Quality 4.
Mode : Graphics X ->	Sets up to perform standard printing. There are two patterns: Graphics 1 and Graphics 2. Graphics 2 is the initial setting.
Mode : Banner X ->	Sets up to perform high-speed printing. There are two patterns: Banner 1 and Banner 2.

Details of print mode

Print Mode	Resolution	Pass	Direction	Initial values for effect
Quality 1	1440 × 1440	16 pass	Uni (unidirectional)	Fine & Fog
Quality 2	1440 × 1440	16 pass	Bi (bidirectional)	Fine & Fog
Graphics 1	720 × 1440	8 pass	Uni (unidirectional)	Fine & Fog
Graphics 2	720 × 1440	8 pass	Bi (bidirectional)	Fine & Fog
Banner 1	720 × 1080	6 pass	Bi (bidirectional)	Fine & Fog
Banner 2	720 × 720	4 pass	Bi (bidirectional)	Fine & Fog

Effect

Mode : Graphics 2 - >

Sets up the Effect menu.

Set up this menu when you want to improve print quality by adjusting the set print mode.

Setting values

Effect : None

The Effect function is not used.

Effect : Wave

The printing joint will be the wave form.
Print quality may be improved than "None".

Effect : Fog

The printing joint will shade off.
Set up this menu when obvious white lines or uneven print density appear on printed media in "Wave".

Effect : Fine & Fuzz

The printing joint will shade off as the wave form.
Performs the printing at slower speed than "Wave".

Effect : Fine & Fog

The printing joint will shade off.
Set this when there is horizontal unevenness in "Fine & Fuzz".
Prints at a slower speed than "Fine & Fuzz".
This is the initially set value.

Effect : Fine & Wave

Performs the printing at slower speed than "Wave".
Set this menu to improve print quality compared with "Wave".

Effect : A - S. Fine & Wave

Performs "Wave" printing using the half of the print head nozzles.
Since only half of the print head nozzles are used, printing speed becomes about half of "Wave".
Set this menu to improve print quality compared with "Fine & Wave".
This is not displayed if you are using the 5-color set.

Effect : B - S. Fine & Wave

Performs Wave printing using the half of the print head nozzles on the opposite side of "A - S. Fine & Wave".
Since only half of the print head nozzles are used, printing speed becomes about a half of "Wave".
Set this menu to improve print quality compared with "Fine & Wave".
This is not displayed if you are using the 5-color set.

**>2: Adjust Print>

**> 2: Adjust Print >

Sets up when adjusting the printer for the optimum quality of image print.
Before adjusting this setting, enter the thickness of the media.

Submenus

Adj. Print 1: Standard

Adjusts only the print mode in the user type setting which is currently set.

Adj. Print 2: Custom

Adjusts the print modes other than the mode in the user type setting which is currently set.

Adj. Print 1: Standard

Adj. Print 1: Standard

Adjusts only the print mode in the user type setting which is currently set.

 ["1. Confirm pattern" P. 66](#)

 ["2. Rough adjustment pattern" P. 67](#)

 ["3. Fine adjustment pattern" P. 67](#)

Submenus

Adj. 1: Confirm Ptn.

Print the test pattern for the adjustment.
Check before adjusting.

Adj. 2: Rough Pattern

Perform this to adjust large misalignment.
Print Adjust pattern and enter the set value.

Adj. 3: Fine Pattern

Perform this to adjust small misalignment.
Print Adjust pattern and enter the set value.

Adj. Print 2: Custom

Adj. Print 2:	Custom
---------------	--------

Perform adjustment for all patterns (A to I).

 ["1. Confirm pattern" P. 66](#)

 ["2. Rough adjustment pattern" P. 67](#)

 ["3. Fine adjustment pattern" P. 67](#)

Submenus

Adj. 1:	Confirm Ptn.
---------	--------------

The test patterns of A to F will be printed for Adjust print. Check before adjusting.

Adj. 2:	Rough Ptn. ALL
---------	----------------

For printing all rough adjustment patterns from A to I.

Adj. 3:	Rough Pattern A
---------	-----------------

For printing an adjust pattern selected from A to I.

·
·
·

Adj. 11:	Rough Pattern I
----------	-----------------

Adj. 12:	Fine Ptn. ALL
----------	---------------

For printing all fine adjustment patterns from A to I.

Adj. 13:	Fine Pattern A
----------	----------------

For printing an adjust pattern selected from A to I.

·
·
·

Adj. 21:	Fine Pattern I
----------	----------------

Adjustment patterns for each print mode

Print mode	Print mode specifications	Adjustment pattern
Quality 1	1440 x 1440, 16 pass, Uni	B
Quality 2	1440 x 1440, 16 pass, Bi	
Graphics 1	720 x 1440, 8 pass, Uni	H
Graphics 2	720 x 1440, 8 pass, Bi	
Banner 1	720 x 1080, 6 pass, Bi	
Banner 2	720 x 720, 4 pass, Bi	

Steps

1. Print a confirm pattern and check it for printing errors.
2. Print "Rough adjustment pattern" and look for a place that is properly adjusted in the printing result.
 - If you selected "Adj. Print 2: Custom", select "ALL" or "A" to "I".
 - The number printed under the pattern without alignment errors is the adjustment value.
3. Enter the adjustment values.
4. Print "Fine adjustment pattern" and look for a place that is properly adjusted in the printing result.
 - If you selected "Adj. Print 2: Custom", select "ALL" or "A" to "I".
 - The number printed under the pattern without alignment errors is the adjustment value.
5. Enter the adjustment values.

Note

- Warm up the heater before printing the Confirm and Adjustment patterns.
"Warming Up" and "Skip ->Enter" is displayed on Operation panel.
- You can start printing while the printer is warming up.
 ["Starting printing during warming up" P. 50](#)

CAUTION



While "Warming Up" is displayed, do not touch Media guide.
You could burn yourself.

1. Confirm pattern

- Press the [Enter] key to carry out printing.
- Check the printing results. If there are shifting problems, proceed to rough adjustment pattern printing.
- In the picture below, there are misalignments.

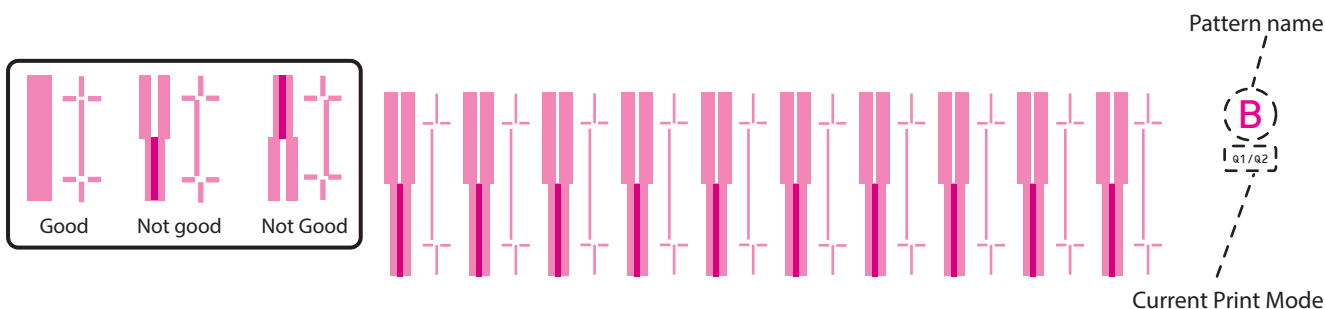

2. Rough adjustment pattern

- Press the [Enter] key to carry out printing.
- Check the print results and select the number that looks most aligned between 1 and 11.
- Pattern names such as "Pattern B: 6" are shown on the display. Use the [+] / [-] key to enter the number of the best-adjusted pattern, and press the [Enter] key.
- In the case of the picture below, enter "7", so that the display reads "Pattern B: 7".

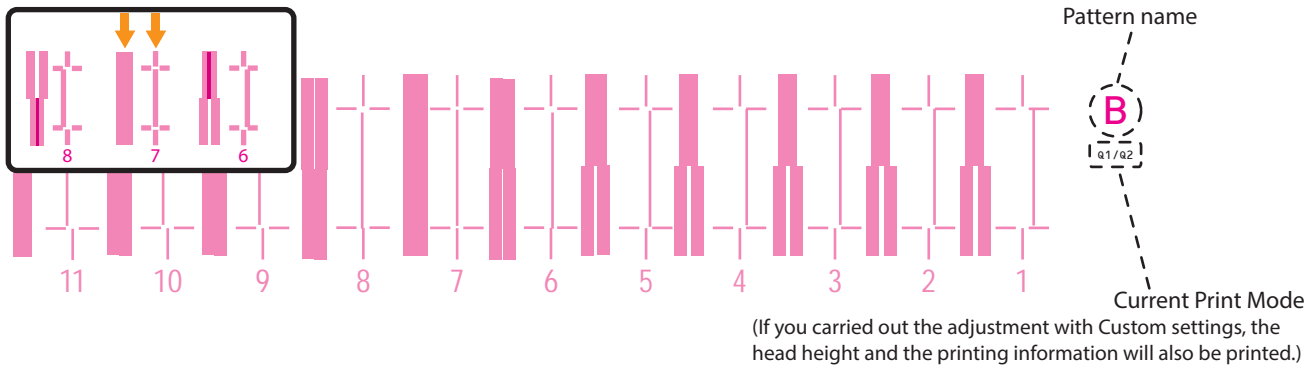

3. Fine adjustment pattern

- Press the [Enter] key to carry out printing. For the Fine adjustment pattern, the same patterns will be printed repeatedly on both sides and center of the media.
- Check the print results on both sides and center of the media and select the number that looks most aligned between 1 and 7.
- Pattern names such as "Pattern B: 4" are shown on the display. Use the [+] / [-] key to enter the number of the best-adjusted pattern, and press the [Enter] key.
- In the case of the picture below, enter "5", so that the display reads "Pattern B: 5".

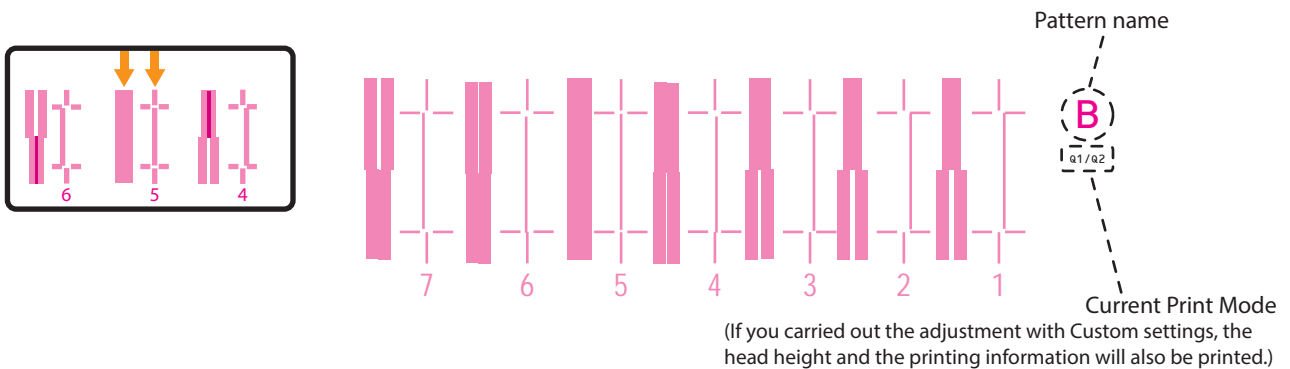

**>3: PF Adjust





**> 3: PF Adjust >

Sets up various settings on the Media feed correction.

When the following defects are found in printing results, they may improve by conducting a media feed correction.

- Images are overlapping.
- There are white lines in images.

Submenus

PF1 : Initial Print	 "PF1: Initial Print" P. 69
PF2 : Initial Change	 "PF2: Initial Change" P. 70
PF3 : Confirm Print	 "PF3: Confirm Print" P. 70
PF4 : Micro Print	 "PF4: Micro Print" P. 71
PF5 : Micro Change	 "PF5: Micro Change" P. 71

Steps

1. Select "PF1: Initial Print".

- "Feed Length: 250 mm" is displayed on Operation panel.

2. After the initial adjustment printing, cut the media.

- Measure the distance between the "✚" in the initial adjustment print using a ruler.

3. Refer to Chapter 1 ["Media feed adjustment steps" P. 48](#) and select "PF2: Initial Change" on the operation panel.

4. Press the [+] key or [-] key on Operation panel and enter the measured value in Step 2.

- Press the [Enter] key to save the initial adjustment value.

5. Press the [+] key or [-] key on Operation panel to select "PF3: Confirm Print".

- "Feed Length: 250 mm" is displayed on Operation panel.

6. After the confirmation adjustment printing, cut the media.

- Measure the distance between the "✚" in the confirmation adjustment print using a ruler. Then, confirm that the distance matches the feeding length when printing.
- If the distance does not match the feeding length, follow the procedure from Step 1 to Step 5 and readjust.
- If the distance matches the feeding length, proceed to Step 7.

7. Refer to Chapter 1 "Media feed adjustment steps" P. 48 and select "PF4: Micro Print" on the operation panel.

- Check the pattern and micro adjustment value.
- In the pattern, look for a place that has least white lines or overlapping in images. The number printed below the adequate pattern is the micro adjustment value.

8. Enter the micro adjustment value according to the printing result in Step 7.

When you know the adjustment value (when changing the media or for similar operations)

1. Enter the adjustment value for "PF5: Micro Change".
2. Select whether you wish to print a confirm pattern and complete the setup.

PF1: Initial Print

PF1 :	Initial Print
-------	---------------

Performs Initial Print.
Enter the "Feed Length" and press the [Enter] key.

Setting values

Feed Length :	250 mm
---------------	--------

100 mm to <250 mm> to 500 mm
<> indicates the initial value.

- After the initial adjustment printing, cut the media.
- With a ruler, measure the length between "⊥" in the pattern.
In the example below, the measured place is shown in orange dotted lines and arrows (the orange parts are not actually printed).

Note

The length of media that is fed (feeding length) for initial adjustment printing is normally set at 250 mm.
If you increase the feeding length, the accuracy of the Media feed adjustment improves.
To change the feeding length, press the [+] key or [-] key on Operation panel and change the set value.

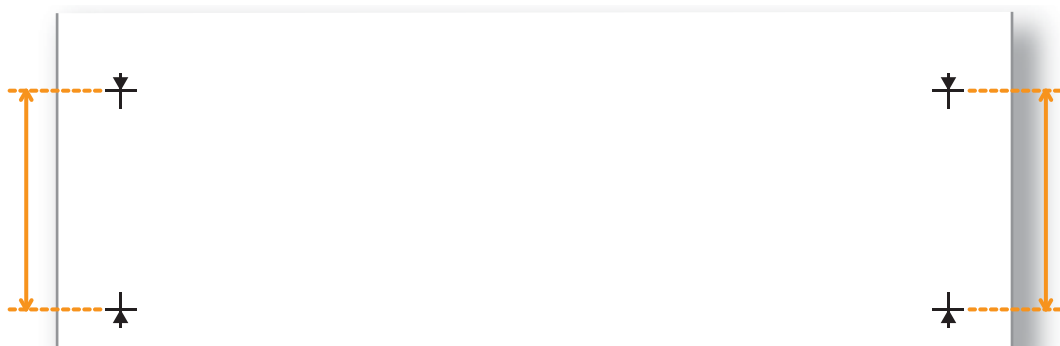

PF2: Initial Change

PF2 : Initial Change

Use the [+] / [-] key to enter the adjustment value, and press the [Enter] key.

Setting values

Init. : 250.0 mm / 250 mm

You can set a value that is between +50 mm and -50 mm of the feed length configured in "Initial Print".

PF3: Confirm Print

PF3 : Confirm Print

Performs Confirm Print.

Enter the "Feed Length" and press the [Enter] key.

Setting values

Feed Length : 250 mm

100 mm to <250 mm> to 500 mm
<> indicates the initial value.

- After the confirmation adjustment printing, cut the media.
- With a ruler, measure the length between "∓" in the pattern. In the example below, the measured place is shown in orange dotted lines and arrows (the orange parts are not actually printed).
- If the measured length does not match the feeding length, re-correct with [PF1: Initial Print](#).
- If the measured length matches the feeding length, proceed to [PF4: Micro Print](#).

Note

The length of media that is fed (feeding length) for confirmation adjustment printing, is normally set at 250 mm.

If you increase the feeding length, the accuracy of the Media feed adjustment improves. To change the feeding length, press the [+] key or [-] key on Operation panel and change the set value.

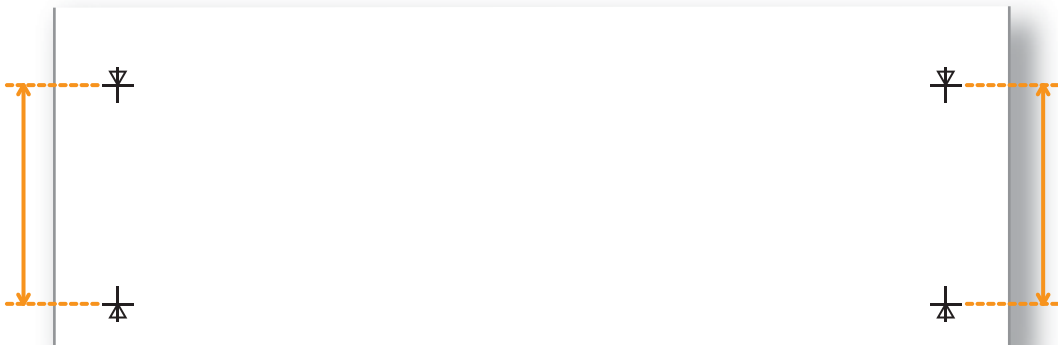

PF4: Micro Print

PF4 : **Micro Print**

Performs Micro adjustment Print.

Enter the appropriate micro adjustment value according to the print result.

- Observe the pattern and verify the micro adjustment value. In the pattern, look for a place that has least white lines or overlapping in images. The number printed below the pattern is the micro adjustment value.

Enter the micro adjustment value according to the print result.

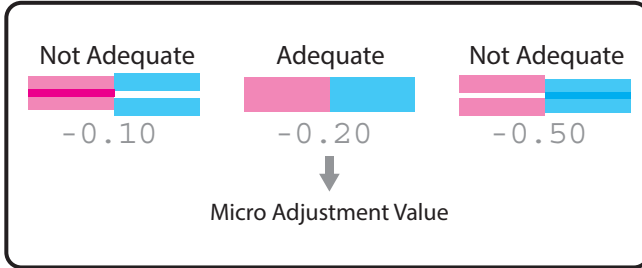

Note

Once an appropriate micro adjustment value has been saved, the value will be the baseline value from the next time to be printed in the center of the pattern. For example, if you have entered "-0.20" and print a micro adjustment pattern, values printed below block pattern will be changed to (from left) +1.00, +0.60, +0.30, 0.00, -0.20 (baseline value), -0.30, -0.40, -0.70, -1.00, -1.40.

PF5: Micro Change

PF5 : **Micro Change**

Use the [+] / [-] key to enter the adjustment value, and press the [Enter] key.

Select whether you wish to perform confirmation print and complete the setup.

Setting values

Micro : 0.00%

-5.00% to <0.00%> to 5.00%

<> indicates the initial value.

**>4: Vacuum Fan

**> 4: Vacuum Fan

Sets up vacuum fan operation.

Use the [+] / [-] key to select the value, and press the [Enter] key.

- If you are using a thin or delicate media and there is risk of it wrinkling due to the fan, set a lower value for the fan.

Setting values

Vacuum Fan : High

<High> / Middle / Low / Off

<> indicates the initial value.

**>5: Thickness

**> 5: Thickness

Sets the thickness of the media you are using.

Use the [+] / [-] key to enter the value, and press the [Enter] key.

Setting values

Thickness : 0.1 mm

0.1 mm to 16.5 mm

<> indicates the initial value.



Note

- This menu is to automatically adjust print quality to a certain extent. If you want to improve print quality, manually adjust it.

 **"**>2: Adjust Print"> P. 64**

- If you have adjusted the print settings, you do not need to configure the thickness of the media in this menu.

**>6: Thickness Adj.

**> 6: Thickness Adj.

Adjusts the head height in accordance with the actual media thickness.

Use the [+] / [-] key to enter the value, and press the [Enter] key.

Setting values

Adjust : 0.0 mm

0.0 mm to 1.5 mm



Important!

If the adjustment value is entered to raise the head height, print quality is not guaranteed.

**>7: Media Initial

****> 7: Media Initial**

Sets whether to detect the media width while initializing the media.

Setting values

Media Init. 1: Height

Set whether or not to detect the media thickness.

Media Init. 2: Media

Set whether or not to detect the media width and top edge.

“Media Init. 1: Height” menu

Media Init. 1: Height

Sets whether to detect the media thickness while initializing the media.

Setting values

Height: Off

The media thickness will not be detected.

Height: On

Detect the media thickness while initializing the media.

This is the initially set value.



Note

Media thickness detection is for stabilizing print quality by keeping the clearance between Print head and media. Detected value may differ from the actual media size.

“Media Init. 2: Media” menu

Media Init. 2: Media

Sets whether to detect the media width and top edge while initializing the media.

Setting values

Media: Off

The media will not be detected.

Media: Top&Width

Detect the media width and edge while initializing the media.

Media: Width

Detect the media width while initializing the media.

This is the initially set value.

**>8: Media Width

****> 8: Media Width**

Sets the width of the current media when the "***>7: Media Initial" is set to "Off".

Use the [+] / [-] key to enter the value, and press the [Enter] key.

If "Media Init.2: Media" in the Media Initial menu is set to "Top&Width" or "Width", the detected width of the media will be displayed.

 "***>7: Media Initial" P. 73

Setting values

Media Width : 1000 mm

182 mm to <1,000 mm> to 1,625 mm

<> indicates the initial value.

**>9: Pass Wait

****> 9: Pass Wait**

Sets the waiting time between passes in multi-strike setting and normal printing.

Setting values

Pass Wait : 0.0 sec

<0.0 sec.> to 5.0 sec.

<> indicates the default setting.

**>10: Rigid / Roll

****> 10: Rigid / Roll**

Set which of roll media or rigid media will be used.

Setting values

Rigid / Roll : Roll

Set when using roll media.

Rigid / Roll : Rigid

Set when using rigid media.



Note

When this menu is set as Roll media and if you print on heavy rigid media, it may cause an error during printing. Also, when this menu is set as Rigid media and if you print on the roll media, it may cause affect print quality.

Make sure that you change the settings deepening on the media type, and then start printing.

**>11: Initial

****> 11: Initial**

Returns all settings of the currently selected User Type to factory default.

Menu 3: Setup

Set 1: Spitting

Set 1: Spitting

Sets up the spitting operation while printing.

The display will shift to setting of the pass count only if "On" is set for "Spitting".

Setting values

Spitting : On

Perform the spitting operation on Spitting box located on the origin side for every shuttle. This is the initially set value.

Spitting : On Media

Perform the spitting operation on the page margins. The printing speed will be improved since the number of time to return to Spitting box is reduced.

Spitting : Off

Spitting operation is not performed.

Note

- Spitting is a maintenance operation for preventing clogging of the print head's nozzles. It consumes ink.
- When Spitting is set to "Off", nozzles will become easily clogged because spitting is not performed. In such a case, print quality cannot be guaranteed.
- When the spitting setting is "On Media", the maximum printable media width becomes 16 mm shorter. Therefore, the side margins become the value that you have set in Side Margin menu +8 mm.

 ["Set 2: Side Margin" P. 76](#)

Pass Count menu

Spitting : On

Enter

Spitting : On Media

This is for setting the interval at which the print head will carry out spitting operation.

- The head will carry out spitting operation every time it completes the number of passes that you set here.

Setting values

Pass Count : 1 cnt

<1 cnt> to 999 cnt
<> indicates the initial value.

Important!

If the number of spitting returns is set high, there is a higher chance of nozzle clogging when printing for a long time. In such a case, print quality cannot be guaranteed.

<Example of spitting operation>

Spitting setting	Pass Count setting	Operation
On	1 cnt	Perform the spitting operation on Spitting box every time Print head returns to the origin position. Spitting operation is not performed over the media.
On	5 cnt	Performs the spitting operation on Spitting box on the origin side every five times Print head returns to the origin position. Spitting operation is not performed over the media.
On Media	1 cnt	Performs the spitting operation on Spitting box on the origin side every time Print head returns to the origin position. Perform the spitting operation on Spitting box every time Print head returns to the origin position.
On Media	5 cnt	Performs the spitting operation on Spitting box on the origin side every five times Print head returns to the origin position. Perform the spitting operation on Spitting box every time Print head returns to the origin position.
Off	—	Spitting is not performed on Spitting box or the media.

Set 2: Side Margin

Set 2: Side Margin

Set up the right and left margins (side margins) while printing.
Use the [+]/[-] key to enter the value, and press the [Enter] key.

Setting values

Side Margin : 5 mm

<5 mm> to 25 mm

<> indicates the initial value.

Note

When the "Spitting menu" is set to "On Media", the maximum printable media width becomes 16 mm shorter.
Therefore, the side margins become the value that you have set in Side Margin menu +8 mm.

 ["Set 1: Spitting" P. 75](#)

Set 3: Take-up

Set 3: Take-up

Sets the media cutting operation after printing.

Setting values

Take-up : Off

The Take-up Unit will not be used.
This is the initially set value.

Take-up : On

Set when using the Take-up Unit.

When the "Take-up" is set to "On"

Take-up : On

Enter

When the "Take-up" is set to "On", the menu is shifted to "Page Gap".
In the "Page Gap menu", you can change the margin setting between images.

Setting values

Page Gap : Normal

The default margin setting between images
will be applied.
This is the initially set value.

Page Gap : Narrow

The margin setting between images is smaller
than Normal.

Set 4: Media Location

Set 4: Media Location

Set the media loading position manually if you are using the media that cannot be detected, such as transparent media.

- Use the [>] / [<] key to move the cursor.
- Use the [+] / [-] key to increase or decrease the value.

Setting values

Side Edge : + 0 0 0 0

Set the right edge position of the media.
The higher the entered value, the further
toward the opposite of the origin side Print
head moves.

- [Enter] key: "Wait for a while" is displayed on
Operation panel, and the LED pointer moves
to the position of the entered value.

Top Edge : + 0 0 0 0

Set the top edge position of the media.
The higher the entered value, the more media
is fed.

Media Width : + 0 0 0 0

Set the media width.
Enter the number for the media width.

Note

- This menu is only available when the "Media Init. 2: Media" is set to "Off" or "Width".

 **"**>7: Media Initial" P. 73**

- This menu is only available for the media that is loaded.
If the media loading position is changed after replacing the media, set this menu again.

Set 5: Origin

Set 5: Origin

Sets the beginning of printing (origin) of the print data.

Setting values

Origin: 0

The origin position is not set.
This is the initially set value.

Origin: On

You can set the origin position.

Origin: On
Enter

Set the menu when reprinting on the margin with changing the printing data position to the printed media.

Use the [+]/[-] key to enter the value, and press the [Enter] key.

Setting values

X: 015.0 mm Y: 0005.0 mm

X (media feeding distance):

15.0 mm to 999.9 mm

Y (print head transferring distance)

5.0 mm to 1,405.0 mm

- [Enter] key:

"Moving Origin Pos." is displayed on Operation panel and Print head moves to the starting position with the LED pointer on.

- After Print head has moved to the origin position, and if you want to change the position, adjust the position using Operation panel again.

Note

Depending on the set value of the side margin, the maximum set value of Y (print head transferring distance) decreases.

 ["Set 2: Side Margin" P. 76](#)

The right side margin will be the following sum depending on the setting.

Y of Origin menu + 8 mm (when the spitting is set to On Media) + Value set in Side Margin menu.

 ["Set 1: Spitting" P. 75](#)

 ["Set 2: Side Margin" P. 76](#)

Set 6: Standby Heating

Set 6: StandbyHeating

Sets up the length of time to preheat the heater while the printer is in standby mode. If printing again during the set time of standby heat, warm-up time can be shortened.

Setting values

Standby : 60 min

10 min to <60 min> / 2 hours / 3 hours / 4 hours
<> indicates the initial value.



Note

The Standby heating function is only available when Blower heater is in the "Printer Link" status.

Set 7: Head Travel

Set 7: Head Travel

Sets up the range that Print head moves while printing.

Setting values

Distance : Data

Print head moves the range of the print data width.

Distance : Machine

Print head moves from origin to the maximum printable media width.

Distance : Media

Print head shifts within the media width. This is the initially set value.

Set 8: Multi Strike

Set 8: Multi Strike

Sets up the overwrite count per line.

Use the [+] / [-] key to enter the value, and press the [Enter] key.

Setting values

Strike Cnt : 1 cnt

<1 cnt> to 9 cnt
<> indicates the initial value.

Set 9: Slant Check

Set 9: Slant Check

Sets up slanting detection during media loading.

Setting values

Media Slant : Off

Slant Check is not performed. This is the initially set value.

Media Slant : On

Slant Check is performed.

Set 10: Auto Cleaning

Set 10: Auto Cleaning

Sets up the range that Print head moves while printing.

Submenus

Auto 1: Waiting >

Set the value for auto cleaning in standby mode.

 ["Waiting Auto Cleaning" P. 80](#)

Auto 2: Printing >

Set the value for auto cleaning during printing.

 ["Printing Auto Cleaning" P. 81](#)

Auto 3: Before Print

Set the value for auto cleaning before printing.

 ["Before Print Auto Cleaning" P. 81](#)

Auto 4: After Print

Set the value for auto cleaning after printing.

 ["After Print Auto Cleaning" P. 81](#)

Auto 5: Power On

Make the settings for auto cleaning when the power is turned ON as well as after recovery from sleep mode.

 ["Power On Auto Cleaning" P. 81](#)

Auto 6: Power Off

Make the settings for auto cleaning when the power is turned OFF.

 ["Power Off Auto Cleaning" P. 82](#)

Note

Even when "Before Print" and "After Print" are set, auto cleaning is not performed for test printing.

Waiting Auto Cleaning

Waiting 1: Type

Select the type for auto cleaning during standby.

When you select "Off", auto cleaning is not performed.

Setting values

Type: Short

Off / <Short> / Normal / Long
<> indicates the initial value.

Waiting 2: Time

Select the interval for auto cleaning.

Setting values

Time: 6 h

1h to <6h> to 24h
<> indicates the initial value.

Important!

If you set the time for Idle auto cleaning longer than the default setting, nozzles may get clogged.

Printing Auto Cleaning

Printing 1:	Type
-------------	------

Select the type for auto cleaning while printing.
When you select "Off", auto cleaning is not performed.

Setting values

Type:	Off	<Off> / Short / Normal / Long <> indicates the initial value.
-------	-----	--

Printing 2:	Time
-------------	------

Select the interval for auto cleaning.

Setting values

Time:	6 h	1h to <6h> to 24h <> indicates the initial value.
-------	-----	--

Before Print Auto Cleaning

Auto 3:	Before Print
---------	--------------

Select the type for before printing auto cleaning.
When you select "Off", auto cleaning is not performed.

Setting values

Before Print:	Off	<Off> / Short / Normal / Long <> indicates the initial value.
---------------	-----	--

After Print Auto Cleaning

Auto 4:	After Print
---------	-------------

Select the type for after printing auto cleaning.
When you select "Off", auto cleaning is not performed.

Setting values

After Print:	Off	<Off> / Short / Normal / Long <> indicates the initial value.
--------------	-----	--

Power On Auto Cleaning

Auto 5:	Power On
---------	----------

Set whether or not to perform cleaning automatically when the power is turned ON as well as after recovery from sleep mode.
When you select "Off", auto cleaning is not performed.

Setting values

Power On:	Short	Off / <Short> / Normal / Long <> indicates the initial value.
-----------	-------	--



When using 5-color configuration, power on cleaning must be performed; therefore the setting is fixed to "On".

Power Off Auto Cleaning

Auto 6: Power Off

Set whether or not to perform cleaning automatically before shutting the printer down. When you select "Off", auto cleaning is not performed.

Setting values

Power Off : Off

<Off> / Short / Normal / Long
<> indicates the initial value.

Set 11: Roll Length

Set 11: Roll Length

Sets up the roll media length.

Setting values

Roll Kind : Off

Roll Length is not used.
This is the initially set value.

Roll Kind : Roll 1

Sets up the roll media length.
The set values of the roll media length can be set as "Roll1" to "Roll3".

Roll Kind : Roll 2

Roll Kind : Roll 3

When the "Roll Kind" is set to "Roll 1", "Roll 2" or "Roll 3"

Length menu

Roll Kind : Roll 1
Enter

Sets up the roll media length.

Setting values

Length : 30 m

1 m to <30 m> to 200 m
<> indicates the initial value.

Print stop menu

Length :	30 m
Enter	

Sets whether or not to display "Roll Remain Error" and pause printing when the length of the roll media that is counted inside the printer becomes 0.

Setting values

Print Stop :	Off
--------------	-----

The roll media remaining count is not used to judge for pausing printing. Printing pauses when the rear sensor responds. This is the initially set value.

Print Stop :	On
--------------	----

Even when the rear sensor does not respond, printing pauses when the roll media remaining count becomes 0.

Note

- Normally you can set this as "Off" as the rear sensor detects when the roll paper is finished.
- If you are using the roll media that does not come off the paper core easily when it is finished, printing may not be paused when the roll media is finished, if the "Print stop menu" is set to "Off". If this happens, set this to "On".

Near End menu

Print Stop :	On
Enter	

Sets whether or not to display "Roll Near End: *m" (* is replaced with a number between 1 and 10) before the length of the roll media that is counted inside the printer becomes 0.

Setting values

Near End :	Off
------------	-----

"Near end" is not displayed. This is the initially set value.

Near End :	Remain * m
------------	------------

"Near end" is displayed when the remaining count for the roll media becomes the length you selected.

Set 12: FrontInterlace

Set 12:	FrontInterlace
---------	----------------

This menu is used to set media edge treatment menu.

Setting values

FrontInterlace :	Auto
------------------	------

<Auto> / Off
<> indicates the initial value.

Set 13: BtmInterlace

Set 12:	FrontInterlace
---------	----------------

Sets the BottomInterlace function.
If the print is missing or blurred, specify "BtmInterlace" to "Off".

Setting values

BtmInterlace :	On
----------------	----

<On> / Off
<> indicates the initial value.

Set 14: Ink Status

Set 14: Ink Status

The amount of ink remaining in each Ink cartridge (ink bag) is displayed. (unit: %)

1 2 3 4 : XX / XX / XX / XX

5 6 7 8 : XX / XX / XX / XX

4-color setting

- 1: Magenta (M)
- 2: Magenta (M)
- 3: Cyan (C)
- 4: Cyan (C)
- 5: Cleaner (Cl)
- 6: Black (K)
- 7: Yellow (Y)

5-color setting

- 1: Black (K)
- 2: Magenta (M)
- 3: Cyan (C)
- 4: Yellow (Y)
- 5: Cleaner (Cl)
- 6: Cleaner (Cl)
- 7: White (Wh)

Note

- To display various information of Ink, use genuine ink and S/C cards.
If Ink other than genuine Ink are used, ink status will not be displayed correctly.
- If it is blinking at 10%, smartchip recovery is being performed on the corresponding ink cartridge.

 ["Smartchip recovery" P. 145](#)

Set 15: Life Times

Set 15: Life Times

Displays the operational life time of each part.

- The lifetime of each part is indicated by the asterisks (Maximum 5 asterisks: 100% left).
As the part deteriorates, the number of asterisks decreases one by one (20%).
- The part should be changed when all of the asterisks have disappeared and "Change" is displayed. Contact your local MUTOH dealer to ask for replacing parts.
- After "Change" appears, "Life Times [Pump]" or a similar message will be displayed when you are not in this menu.
You can delete this message by pressing the [Cancel] key.

Submenus

Head : E*** F

Displays the service life for the print head.
The service life in this case is at 60%.

Pump : E*** F

Displays the service life for the pump.

CR Motor : Change

Displays the service life for the CR motor.
The service life of the component in this case is over.
Have the component replaced.

PF Motor : E**** F

Displays the service life for the PF motor.

C Pump : E*** F

Displays the service life for the Circulation pump.

Set 16: Header Dump

Set 16: Header Dump

Sets whether to print the following information when printing.

- Data header
- Data dot number (printed only when Header dump setting is "On")
- Printing date and time
- Printer serial number
- Firmware version
- Receiving time (printed only when Header dump setting is "Dump")
- Receiving size (printed only when Header dump setting is "Dump")

Setting values

Header Dump : Off

Dump data is not printed.
This is the initially set value.

Header Dump : On

Dump data is printed after the original image is printed.

Header Dump : Dump

Prints only dump data.
"Data dot number" is not printed.

Header Dump : Print

Prints the last header dump.
If no history is available, "No Print Data" will appear on the operation panel.

Note

- The data will be useful when contacting technical support.
- Performing printing if the printer is connected to PC, the print settings of RIP soft you are using are printed on data header.

Set 17: Start Feed

Set 17: Start Feed

You can change the margin setting between images.

- Value over 0: The margin setting between images will be wider than when setting "0".
- Value equal to 0: The default margin setting between images will be applied.
- Value below 0: The margin setting between images will be smaller than when setting "0".

Setting values

Start Feed : 150 mm

-10 mm to <150 mm> to 500.0 mm
<> indicates the initial value.

Note

With take-up system: if you want to set "Start Feed" to below 0, set "Page Gap" to "Narrow".
If not, the Start Feed setting is not reflected properly.

 **"When the "Take-up" is set to "On" P. 77**

Set 18: Obstacle Check

Set 18: Obstacle Check

Enable or disable the head strike prevention sensor to detect obstacles.

 ["Head strike prevention sensor" P. 27](#)

Setting values

Obstacle Check: Off

Disable the sensor.

Obstacle Check: On

Enable the sensor to detect obstacles.
This is the initially set value.

Set 19: Initialization

Set 19: Initialization

Returns the settings of the printer to default.

Submenus

Init: ALL

For initializing the settings of all the menus.

Init: UserType

Initializes the settings in the User Type menu.

Set 20: Temporary

Set 20: Temporary

Displays the menus which have been set to hide in the "Menu4: Menu Option" temporarily.

Press the [Enter] key to return to the previous menu with all set up items displayed.

Menu 4: Test Print

Test 1: Nozzle Check

Test 1: Nozzle Check

Use this menu to check that the print head and print nozzles you selected can properly print without nozzle clogging and missing or too light lines.

 ["Nozzle check" P. 43](#)

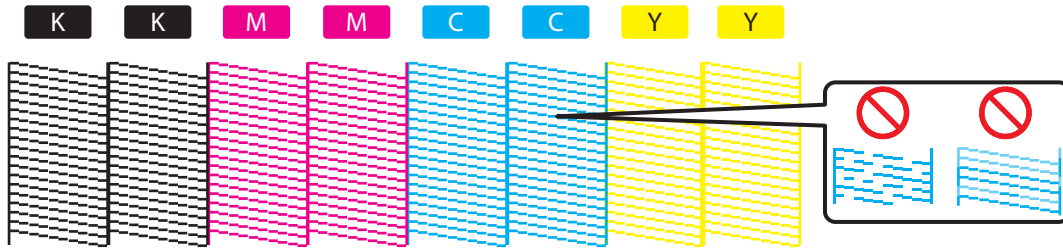

Note

- The above pattern is the example when the printer is set to 4-color setting.
- The printer information (date and time of printing, printer's serial number, firmware version) is printed on the nozzle check pattern.

Test 2: Nozzle Check B

Test 2: Nozzle Check B

The background for some of the nozzle check pattern is printed in color so that the nozzle condition is easy to see.

- Part of the background for the white nozzles is black.
- The background of the KCMY nozzles are white.

 ["Nozzle check" P. 43](#)

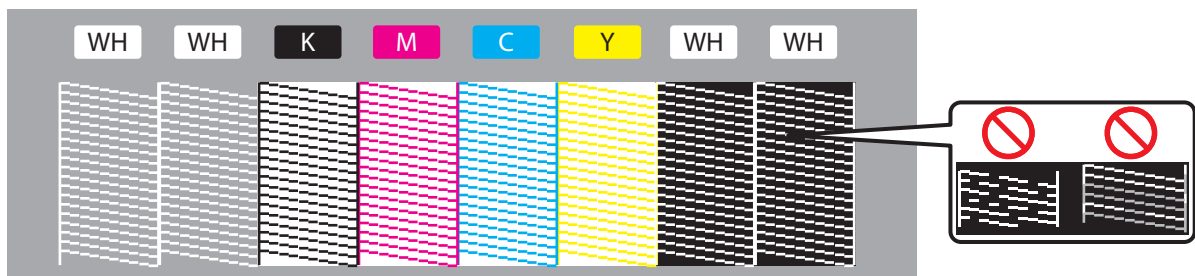

Note

- "Nozzle Check B" will only appear in the menu if the printer is set to 5-color configuration.
- The printer information (date and time of printing, printer's serial number, firmware version) is printed on the nozzle check pattern.

Test 3: Mode Print

Test 3: Mode Print

Mode print can be performed. Used to confirm the following printing conditions.

- Print quality
- Effect
- Micro adjustment value for feed correction

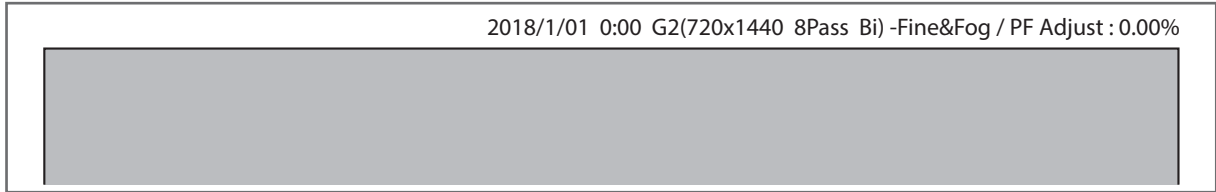

Test 4: Setup List

Test 4: Setup List

Setup list printing is performed.

Use this to check the current setting contents and the User Type.

Setup List

Setup List		Head Height/Low	Cleaning	Mode/Normal
<Information>				
Serial No.	-----	Model	-----	2018/01/01 0:00
Model	→ G2720H	Firmware M	→ V.X.X	0:Name []
Memory Size	→ 168MB			1:Name []
<Menu Setup>				
[Setup] [Number] [Select] Menu		[Number] [Menu]		
[1] [1] [User Type] → Type 1		[1] [0] Maintenance → Setup		
[2] [1] [Print Mode] → Graphics 2 Effect → Fine&Fog		[2] [0] Appearance []		
[3] [2] [2] [Adjust Print] → Graphics 2 Effect → Fine&Fog		[3] [0] Language []		
[4] [2] [3] [PF Adjust] → 250.0/250.0mm		[4] [0] Longstone []		
[5] [2] [4] [Initial Adj. Print] → 0.00%		[5] [0] Basic Cleaning []		
[6] [2] [5] [Carriage Adj. Print] → 0.00%		[6] [0] Waiting Time []		
[7] [2] [6] [Micro Adjust] → 0.00%		[7] [0] Printing Time []		
[8] [2] [7] [Heater (Slipper)] → Off		[8] [0] Before Print []		
[9] [2] [8] [Heater (Lower)] → Off		[9] [0] Sleep Mode []		
[10] [2] [9] [Vacuum Fan] → High		[10] [0] Sleep Mode []		
[11] [2] [10] [Thickness] → 170µm		[11] [0] Sleep Mode []		
[12] [2] [11] [Media Initial] → Width		[12] [0] Sleep Mode []		
[13] [2] [12] [Media Width] → 95.0mm		[13] [0] Sleep Mode []		
[14] [2] [13] [Roll Feed] → Roll 1 (Length) → 2bay		[14] [0] Sleep Mode []		
[15] [2] [14] [Roll Feed] → Roll 1 (Length) → 2bay		[15] [0] Sleep Mode []		
[16] [2] [15] [Roll Feed] → Roll 1 (Length) → 2bay		[16] [0] Sleep Mode []		
[17] [2] [16] [Roll Feed] → Roll 1 (Length) → 2bay		[17] [0] Sleep Mode []		
[18] [2] [17] [Roll Feed] → Roll 1 (Length) → 2bay		[18] [0] Sleep Mode []		
[19] [2] [18] [Roll Feed] → Roll 1 (Length) → 2bay		[19] [0] Sleep Mode []		
[20] [2] [19] [Roll Feed] → Roll 1 (Length) → 2bay		[20] [0] Sleep Mode []		
[21] [2] [20] [Roll Feed] → Roll 1 (Length) → 2bay		[21] [0] Sleep Mode []		
[22] [2] [21] [Roll Feed] → Roll 1 (Length) → 2bay		[22] [0] Sleep Mode []		
[23] [2] [22] [Roll Feed] → Roll 1 (Length) → 2bay		[23] [0] Sleep Mode []		
[24] [2] [23] [Roll Feed] → Roll 1 (Length) → 2bay		[24] [0] Sleep Mode []		
[25] [2] [24] [Roll Feed] → Roll 1 (Length) → 2bay		[25] [0] Sleep Mode []		
[26] [2] [25] [Roll Feed] → Roll 1 (Length) → 2bay		[26] [0] Sleep Mode []		
[27] [2] [26] [Roll Feed] → Roll 1 (Length) → 2bay		[27] [0] Sleep Mode []		
[28] [2] [27] [Roll Feed] → Roll 1 (Length) → 2bay		[28] [0] Sleep Mode []		
[29] [2] [28] [Roll Feed] → Roll 1 (Length) → 2bay		[29] [0] Sleep Mode []		
[30] [2] [29] [Roll Feed] → Roll 1 (Length) → 2bay		[30] [0] Sleep Mode []		
[31] [2] [30] [Roll Feed] → Roll 1 (Length) → 2bay		[31] [0] Sleep Mode []		
[32] [2] [31] [Roll Feed] → Roll 1 (Length) → 2bay		[32] [0] Sleep Mode []		
[33] [2] [32] [Roll Feed] → Roll 1 (Length) → 2bay		[33] [0] Sleep Mode []		
[34] [2] [33] [Roll Feed] → Roll 1 (Length) → 2bay		[34] [0] Sleep Mode []		
[35] [2] [34] [Roll Feed] → Roll 1 (Length) → 2bay		[35] [0] Sleep Mode []		
[36] [2] [35] [Roll Feed] → Roll 1 (Length) → 2bay		[36] [0] Sleep Mode []		
[37] [2] [36] [Roll Feed] → Roll 1 (Length) → 2bay		[37] [0] Sleep Mode []		
[38] [2] [37] [Roll Feed] → Roll 1 (Length) → 2bay		[38] [0] Sleep Mode []		
[39] [2] [38] [Roll Feed] → Roll 1 (Length) → 2bay		[39] [0] Sleep Mode []		
[40] [2] [39] [Roll Feed] → Roll 1 (Length) → 2bay		[40] [0] Sleep Mode []		
[41] [2] [40] [Roll Feed] → Roll 1 (Length) → 2bay		[41] [0] Sleep Mode []		
[42] [2] [41] [Roll Feed] → Roll 1 (Length) → 2bay		[42] [0] Sleep Mode []		
[43] [2] [42] [Roll Feed] → Roll 1 (Length) → 2bay		[43] [0] Sleep Mode []		
[44] [2] [43] [Roll Feed] → Roll 1 (Length) → 2bay		[44] [0] Sleep Mode []		
[45] [2] [44] [Roll Feed] → Roll 1 (Length) → 2bay		[45] [0] Sleep Mode []		
[46] [2] [45] [Roll Feed] → Roll 1 (Length) → 2bay		[46] [0] Sleep Mode []		
[47] [2] [46] [Roll Feed] → Roll 1 (Length) → 2bay		[47] [0] Sleep Mode []		
[48] [2] [47] [Roll Feed] → Roll 1 (Length) → 2bay		[48] [0] Sleep Mode []		
[49] [2] [48] [Roll Feed] → Roll 1 (Length) → 2bay		[49] [0] Sleep Mode []		
[50] [2] [49] [Roll Feed] → Roll 1 (Length) → 2bay		[50] [0] Sleep Mode []		
[51] [2] [50] [Roll Feed] → Roll 1 (Length) → 2bay		[51] [0] Sleep Mode []		
[52] [2] [51] [Roll Feed] → Roll 1 (Length) → 2bay		[52] [0] Sleep Mode []		
[53] [2] [52] [Roll Feed] → Roll 1 (Length) → 2bay		[53] [0] Sleep Mode []		
[54] [2] [53] [Roll Feed] → Roll 1 (Length) → 2bay		[54] [0] Sleep Mode []		
[55] [2] [54] [Roll Feed] → Roll 1 (Length) → 2bay		[55] [0] Sleep Mode []		
[56] [2] [55] [Roll Feed] → Roll 1 (Length) → 2bay		[56] [0] Sleep Mode []		
[57] [2] [56] [Roll Feed] → Roll 1 (Length) → 2bay		[57] [0] Sleep Mode []		
[58] [2] [57] [Roll Feed] → Roll 1 (Length) → 2bay		[58] [0] Sleep Mode []		
[59] [2] [58] [Roll Feed] → Roll 1 (Length) → 2bay		[59] [0] Sleep Mode []		
[60] [2] [59] [Roll Feed] → Roll 1 (Length) → 2bay		[60] [0] Sleep Mode []		
[61] [2] [60] [Roll Feed] → Roll 1 (Length) → 2bay		[61] [0] Sleep Mode []		
[62] [2] [61] [Roll Feed] → Roll 1 (Length) → 2bay		[62] [0] Sleep Mode []		
[63] [2] [62] [Roll Feed] → Roll 1 (Length) → 2bay		[63] [0] Sleep Mode []		
[64] [2] [63] [Roll Feed] → Roll 1 (Length) → 2bay		[64] [0] Sleep Mode []		
[65] [2] [64] [Roll Feed] → Roll 1 (Length) → 2bay		[65] [0] Sleep Mode []		
[66] [2] [65] [Roll Feed] → Roll 1 (Length) → 2bay		[66] [0] Sleep Mode []		
[67] [2] [66] [Roll Feed] → Roll 1 (Length) → 2bay		[67] [0] Sleep Mode []		
[68] [2] [67] [Roll Feed] → Roll 1 (Length) → 2bay		[68] [0] Sleep Mode []		
[69] [2] [68] [Roll Feed] → Roll 1 (Length) → 2bay		[69] [0] Sleep Mode []		
[70] [2] [69] [Roll Feed] → Roll 1 (Length) → 2bay		[70] [0] Sleep Mode []		
[71] [2] [70] [Roll Feed] → Roll 1 (Length) → 2bay		[71] [0] Sleep Mode []		
[72] [2] [71] [Roll Feed] → Roll 1 (Length) → 2bay		[72] [0] Sleep Mode []		
[73] [2] [72] [Roll Feed] → Roll 1 (Length) → 2bay		[73] [0] Sleep Mode []		
[74] [2] [73] [Roll Feed] → Roll 1 (Length) → 2bay		[74] [0] Sleep Mode []		
[75] [2] [74] [Roll Feed] → Roll 1 (Length) → 2bay		[75] [0] Sleep Mode []		
[76] [2] [75] [Roll Feed] → Roll 1 (Length) → 2bay		[76] [0] Sleep Mode []		
[77] [2] [76] [Roll Feed] → Roll 1 (Length) → 2bay		[77] [0] Sleep Mode []		
[78] [2] [77] [Roll Feed] → Roll 1 (Length) → 2bay		[78] [0] Sleep Mode []		
[79] [2] [78] [Roll Feed] → Roll 1 (Length) → 2bay		[79] [0] Sleep Mode []		
[80] [2] [79] [Roll Feed] → Roll 1 (Length) → 2bay		[80] [0] Sleep Mode []		
[81] [2] [80] [Roll Feed] → Roll 1 (Length) → 2bay		[81] [0] Sleep Mode []		
[82] [2] [81] [Roll Feed] → Roll 1 (Length) → 2bay		[82] [0] Sleep Mode []		
[83] [2] [82] [Roll Feed] → Roll 1 (Length) → 2bay		[83] [0] Sleep Mode []		
[84] [2] [83] [Roll Feed] → Roll 1 (Length) → 2bay		[84] [0] Sleep Mode []		
[85] [2] [84] [Roll Feed] → Roll 1 (Length) → 2bay		[85] [0] Sleep Mode []		
[86] [2] [85] [Roll Feed] → Roll 1 (Length) → 2bay		[86] [0] Sleep Mode []		
[87] [2] [86] [Roll Feed] → Roll 1 (Length) → 2bay		[87] [0] Sleep Mode []		
[88] [2] [87] [Roll Feed] → Roll 1 (Length) → 2bay		[88] [0] Sleep Mode []		
[89] [2] [88] [Roll Feed] → Roll 1 (Length) → 2bay		[89] [0] Sleep Mode []		
[90] [2] [89] [Roll Feed] → Roll 1 (Length) → 2bay		[90] [0] Sleep Mode []		
[91] [2] [90] [Roll Feed] → Roll 1 (Length) → 2bay		[91] [0] Sleep Mode []		
[92] [2] [91] [Roll Feed] → Roll 1 (Length) → 2bay		[92] [0] Sleep Mode []		
[93] [2] [92] [Roll Feed] → Roll 1 (Length) → 2bay		[93] [0] Sleep Mode []		
[94] [2] [93] [Roll Feed] → Roll 1 (Length) → 2bay		[94] [0] Sleep Mode []		
[95] [2] [94] [Roll Feed] → Roll 1 (Length) → 2bay		[95] [0] Sleep Mode []		
[96] [2] [95] [Roll Feed] → Roll 1 (Length) → 2bay		[96] [0] Sleep Mode []		
[97] [2] [96] [Roll Feed] → Roll 1 (Length) → 2bay		[97] [0] Sleep Mode []		
[98] [2] [97] [Roll Feed] → Roll 1 (Length) → 2bay		[98] [0] Sleep Mode []		
[99] [2] [98] [Roll Feed] → Roll 1 (Length) → 2bay		[99] [0] Sleep Mode []		
[100] [2] [99] [Roll Feed] → Roll 1 (Length) → 2bay		[100] [0] Sleep Mode []		

User Type List

<User Type List>					
User Type	Type 1	Type 2	Type 3	Type 4	Type 5
Print Mode	Graphics 2	Graphics 2	Graphics 2	Graphics 2	Graphics 2
Print Mode > Effect	Fine&Fog	Fine&Fog	Fine&Fog	Fine&Fog	Fine&Fog
PF > Initial Adjust	250.0 / 250.0mm	250.0 / 250.0mm	250.0 / 250.0mm	250.0 / 250.0mm	250.0 / 250.0mm
PF > Micro Adjust	0.00%	0.00%	0.00%	0.00%	0.00%
Heater (Slipper)	Off	Off	Off	Off	Off
Heater (Lower)	Off	Off	Off	Off	Off
Vacuum Fan	High	High	High	High	High
Thickness	170µm	170µm	170µm	170µm	170µm
User Type	Type 6	Type 7	Type 8	Type 9	Type 10
Print Mode	Graphics 2	Graphics 2	Graphics 2	Graphics 2	Graphics 2
Print Mode > Effect	Fine&Fog	Fine&Fog	Fine&Fog	Fine&Fog	Fine&Fog
PF > Initial Adjust	250.0 / 250.0mm	250.0 / 250.0mm	250.0 / 250.0mm	250.0 / 250.0mm	250.0 / 250.0mm
PF > Micro Adjust	0.00%	0.00%	0.00%	0.00%	0.00%
Heater (Slipper)	Off	Off	Off	Off	Off
Heater (Lower)	Off	Off	Off	Off	Off
Vacuum Fan	High	High	High	High	High
Thickness	170µm	170µm	170µm	170µm	170µm
User Type	Type 11	Type 12	Type 13	Type 14	Type 15
Print Mode	Graphics 2	Graphics 2	Graphics 2	Graphics 2	Graphics 2
Print Mode > Effect	Fine&Fog	Fine&Fog	Fine&Fog	Fine&Fog	Fine&Fog
PF > Initial Adjust	250.0 / 250.0mm	250.0 / 250.0mm	250.0 / 250.0mm	250.0 / 250.0mm	250.0 / 250.0mm
PF > Micro Adjust	0.00%	0.00%	0.00%	0.00%	0.00%
Heater (Slipper)	Off	Off	Off	Off	Off
Heater (Lower)	Off	Off	Off	Off	Off
Vacuum Fan	High	High	High	High	High
Thickness	170µm	170µm	170µm	170µm	170µm

Test 5: Palette

Test 5: Palette

Palette print is executed for the color demonstration.



Note

When the selected print mode of the user type is Banner 1, Palette menu is not displayed.

☞ *****>1: Print Mode" P.62**

Menu 5: Cleaning

Perform Head cleaning.

Time : Short

Consumes less ink than Normal cleaning.

Time : Normal

Conduct nozzle check before and after printing, and use when nozzle missing is found.

Time : Long

Consumes more ink than Normal cleaning. When nozzle missing still occurs after Normal cleaning, conduct Long cleaning.

Time : LittleCharge

Though much better cleaning results can be expected than Long cleaning, it consumes a large amount of ink.

Time : InitialCharge

Gives a rather higher cleaning effect than "LittleCharge", but also consumes rather more ink.

Menu 6: Menu Option

You can choose whether to display the menus in “Menu 3: Setup”.
Choose whether you wish to display a menu by pressing the [Enter] key.

[*]= the item will be displayed

[]= the item will not be displayed

1: [*]	Spitting
--------	-----------------

Displays the “Spitting menu”.
The initial value is [*].

2: [*]	Side Margin
--------	--------------------

Displays the “Side Margin menu”.
The initial value is [*].

3: [*]	Take-up
--------	----------------

Displays the “Take-up menu”.
The initial value is [*].

⋮

⋮

19: [*]	Initialization
---------	-----------------------

Displays the “Initialization menu”.
The initial value is [].

20:	ALL On
-----	---------------

If you press the [Enter] key, all the items in Menu Option will be marked with a [*] (displayed).

21:	ALL Off
-----	----------------

If you press the [Enter] key, all the items in Menu Option will be marked with a [] (not displayed).

Menu 7: Maintenance

Maintenance 1: Daily Maintenance

Mnt. 1: Daily Maintenance

Use this menu in following cases:

- If the nozzle missing still persists after performing head cleaning.
- If you perform printing all day without entering to sleep mode and you need to perform daily maintenance.

 ["Continuously using printer after daily maintenance" P. 118](#)

Submenus

Daily Maint. : Start

Press the [Enter] key to start maintenance.

Daily Maint. : End

After the maintenance is complete, press the [Enter] key.

- The printer automatically performs the Short cleaning.



To perform daily maintenance after using the printer for the day, see ["Daily Maintenance" P. 108.](#)

Maintenance 2: Long Storage

Mnt. 2: Long Storage

After washing Print head with the cleaning fluid, Print head is filled with the cleaning fluid. In the following situations, perform long storage and then turn the printer OFF.

- When the printer is turned off for over 24 hours.
- When you may not be able to run a weekly cleaning on the printer that is in sleep mode.

See below for the procedure.

 ["Long Storage and Initial Charge" P. 131](#)

Maintenance 3: Cap Out

Mnt. 3: Cap Out

Used in the following cases.

- Replacing absorption material for the flushing box
- Replacing the cleaning wiper

 ["Maintenance" P. 98](#)

Submenus

Cap Out : Start

Press the [Enter] key to perform replacement.

- The carriage moves to the center of the printer.
- The cleaning wiper moves upward.

Cap Out : End

After the replacement is complete, press the [Enter] key.

- The printer moves the carriage and the cleaning wiper back to each original position.

Maintenance 4: Longstore

Mnt. 4: Longstore

Flush the print head using cleaning fluid and discharge the fluid from the printer.

Use this menu before transporting.

See below for the procedure.

 ["Transporting the printer" P. 130](#)

Maintenance 5: Ink Replace

Mnt. 5: Ink Replace

Replace the ink in some of the ink tubes with the cleaning fluid.

- This menu will only appear in 5-color configuration.
- After ink has been replaced with cleaning fluid, printing is not possible.

To perform printing, use "Mnt.6: Wash Replace" and replace cleaning fluid with ink.

 ["Maintenance 6: Wash Replace" P. 92](#)

Maintenance 6: Wash Replace

Mnt. 6: Wash Replace

Replace the cleaning ink in some of the ink tubes with ink.

- This menu will only appear in 5-color configuration.

Maintenance 7: Color Maintenance

Mnt. 7: Color Mainte.

The printer performs a color ink maintenance when powered on or waking up from over 24 hours of sleep mode.

If variations in color on the print is noticeable, choose ON to enable the color maintenance.

Setting values

Color Mnt.: OFF

The printer does not perform the color ink maintenance.

This is the initially set value.

Color Mnt.: ON

The printer performs the color ink maintenance.

It consumes high amount of ink.

Menu 8: Version

Menu 8: Version >

Displays the versions of the firmware.

Ver. M / H : X.XX / X.XX

Displays the versions of the firmware on the main (M) and heater (H) sides.

Menu 9: Initial

Initial 1: Language

Initial 1: Language

For setting the language that will be displayed.

Setting values

Language: エイゴ English

Displays will be in English.
This is the initially set value.

Language: ニホンゴ Japanese

Displays will be in Japanese.

Initial 2: Length

Initial 2: Length

For setting the length units that will be displayed.

Setting values

Length: mm

Displays the length in millimeters (mm).
This is the initially set value.

Length: inch

Displays the length in inches (inch).

Initial 3: IP Address

Initial 3: IP Address

Sets the IP address of the printer.

- Use the [+] key to increase a setting value.
- Use the [-] key to decrease a setting value.
- Press the [Enter] key to confirm your input for a value. The cursor will move on to the next setting value.
- Confirm your input for each value.

Setting values

IP: 192. 168. 1. 253

0.0.0.0 to <192.168.1.253> to 255.255.255.255
<> indicates the initial value.



Note

Be sure to set the IP address, the Subnet Mask, and the Gateway after consulting the network administrator.

Initial 4: Subnet Mask

Initial 4: Subnet Mask

Sets the subnet mask of the printer.

- Use the [+] key to increase a setting value.
- Use the [-] key to decrease a setting value.
- Press the [Enter] key to confirm your input for a value. The cursor will move on to the next setting value.
- Confirm your input for each value.

Setting values

MASK: 255. 255. 255. 0

0.0.0.0 to <255.255.255.0> to 255.255.255.255
<> indicates the initial value.

Initial 5: Gateway

Initial 5: Gateway

Sets the gateway.

- Use the [+] key to increase a setting value.
- Use the [-] key to decrease a setting value.
- Press the [Enter] key to confirm your input for a value. The cursor will move on to the next setting value.
- Confirm your input for each value.

Setting values

GW: 192. 168. 1. 254

0.0.0.0 to <192.168.1.254> to 255.255.255.255
<> indicates the initial value.

Initial 6: Alert Buzzer

Initial 6: Alert Buzzer

Selects how to turn off the printer beep sound when an error occurs.

For unattended printing, you can select "Off" setting to avoid continuous buzzer beep.

Submenus

Alert Buzzer : On

Press any key on Operation panel to turn off beep sound.

This is the initially set value.

Alert Buzzer : Off

After several beeps, the printer automatically turns off beep sound.

Menu 10: Job Status

Menu 10: Job Status >

Various information of previous print will be displayed.

JobStatus : Completed

Displays if the print is completed.

- When the print is completed: [Completed]
- When the print is canceled: [Canceled]

ToDoLength : XXX.X m

The total length of print data (media feeding direction) will be displayed.

Done : XXX.X m

The printed length will be displayed.

Remain : XXX.X m

The remaining length of print data will be displayed.

Note

- The values displayed in this function are just standard values, not guarantee the accuracy.
- If the print data includes no length data, all information will be displayed as "0".
- This function is to check the information of print data with the print operation is completed. For the details on data while printing, please refer to the ["Menu 3: Job Status" P. 52](#) under ["What you can do on the operation panel during printing" P. 51](#).

Chapter 3 Maintenance

Maintenance.....	98
Agitating ink.....	99
Agitating ink.....	99
Checking and replacing ink.....	101
Checking ink level.....	101
When it becomes time to replace ink.....	102
Replacing ink.....	102
Replacing Adapter's plug for High capacity ink pack adapter.....	104
Emptying waste fluid tank.....	105
Emptying waste fluid tank.....	105
Daily Maintenance.....	108
Flow of Daily Maintenance.....	108
Preparing for Daily Maintenance.....	109
Performing Daily Maintenance.....	111
Continuously using printer after daily maintenance.....	118
Cleaning each part.....	120
Head cleaning.....	120
Inside cleaning.....	122
Replacing consumable parts.....	123
Replacing absorption material for the flushing box.....	123
Replacing the cleaning wiper.....	127
Moving or transporting the printer.....	129
Moving the printer.....	129
Transporting the printer.....	130
Long Storage and Initial Charge.....	131
If not using the printer for a long period of time.....	131
Performing Long Storage.....	132
Performing initial charging after head cleaning.....	136

Maintenance

To maintain the performance of this product, please conduct maintenance by yourself.
The types of maintenance are shown next.

Before and after daily operation	"Agitating ink" P. 99 "Nozzle check and cleaning" P. 43
After daily operations	"Daily Maintenance" P. 108
Based on your usage condition	"Head cleaning" P. 120 "Replacing ink" P. 102 "Replacing Adapter's plug for High capacity ink pack adapter" P. 104 "Emptying waste fluid tank" P. 105 "Replacing absorption material for the flushing box" P. 123
Monthly	"Inside cleaning" P. 122
Every six months	"Replacing the cleaning wiper" P. 127
When not used for a week or more	"Head cleaning" P. 120 (Once a week)

Important!

Since a service technician has to handle following cases, please contact your local MUTOH dealer.

- Error requiring restart is happening repeatedly.
- The message to notify the life of motor, pump is displayed.

 ["Messages and Error Messages" P. 140](#)

Agitating ink

Agitating ink

Agitate the ink at the following times to prevent it from settling out and/or coagulating:

- Before installing new ink
- When any of the messages below appears

5-color configuration:

Shake W Cartridge

Agitate the White (Wh) ink.

- Displays every 12 hours.

Shake KMCY Cartridge

Agitate the Black (K), Magenta (M), Cyan (C), and Yellow (Y) ink.

- Displays every 72 hours.

Shake ALL Cart.

Agitate all ink.

4-color configuration:

Shake ALL Cart.

Agitate the Black (K), Magenta (M), Cyan (C), and Yellow (Y) ink.

- Displays every 72 hours.

Important!

- **Agitate the ink periodically. Otherwise, the ink settles or coagulates and may cause poor print quality or a malfunction.**
- **You should agitate the ink when the message appears. Otherwise, for 12 hours after the message appears, you will repeatedly have to wait a certain time before you can print. When 12 hours have passed, the printer will not print any data. In either case, you can restore the printer to normal condition by agitating the ink.**

CAUTION



Wear protective equipment (gloves, goggles or eye protection, protective mask, protective clothing) when handling ink.

Be cautious that ink does not get into your eye or make a contact with your skin.

When ink gets into your eye or make a contact with your skin, wash with water immediately. If left as it is, it may cause red eye or light inflammation. If it is necessary, please see your doctor immediately.



Steps

Note

For proper instructions of High capacity ink pack adapter, see the High Capacity Ink Pack Adapter Operation Manual.

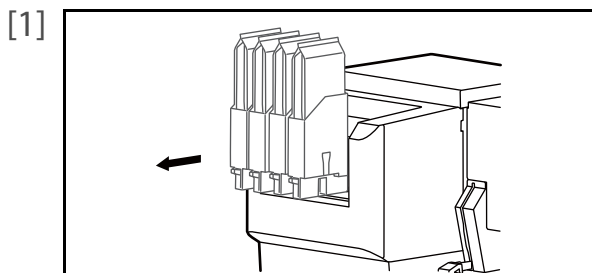

Remove High capacity ink pack adapters from the ink cartridge slots.

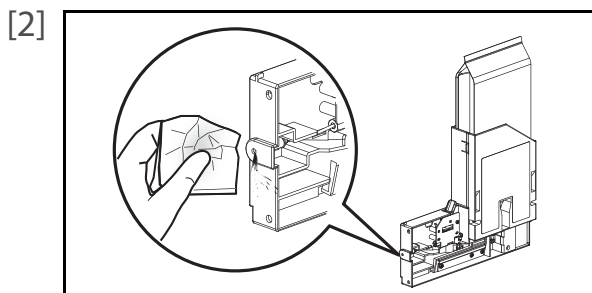

Using the paper towel provided with the printer to wipe off the ink attached to the insertion point for High capacity ink pack adapters.

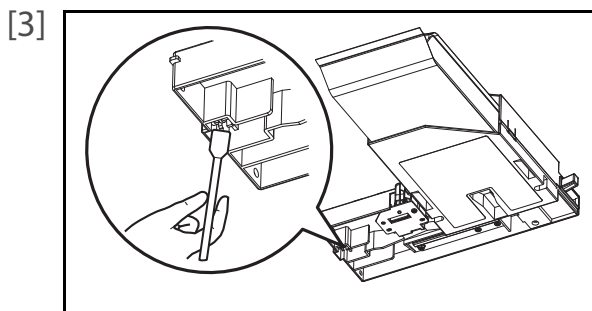

Tilt High capacity ink pack adapters, use cleaning stick provided with the printer, and absorb the ink collected around the tube connectors.

- Tilt High capacity ink pack adapter so that the caution label is facing down.
- Tilt High capacity ink pack adapter so that the insertion point is lowered a little.

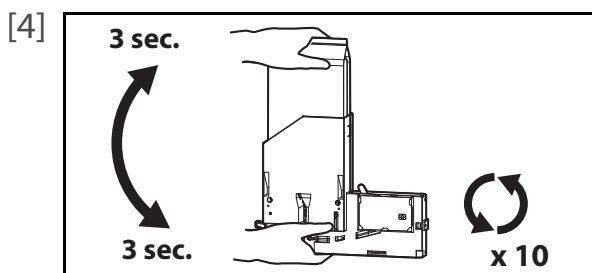

- To prevent the ink bag and the High capacity ink pack adapter from separating, hold one hand against the top of the ink bag. Rotate the plug of the ink bag vertically and hold for 3 seconds.
- Then, invert the ink bag with the adapter and hold for 3 seconds.
- Repeat that 10 times.

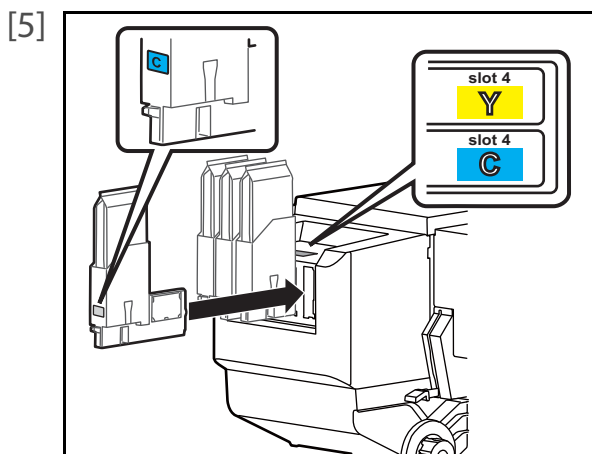

Re-insert the High capacity ink pack adapters into Ink cartridge slots.

- Make sure to match the ink pack color with the label of this printer.
- Insert all the way to the end.

Important!

Make sure you insert the High capacity ink pack adapters into the original slots. Even when you have the same color ink packs, do not switch and insert them into different slots.

Checking and replacing ink

Checking ink level

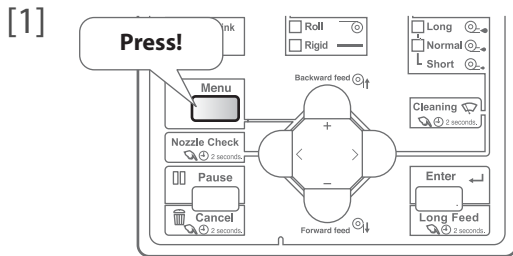

Press the [Menu] key on the operation panel.



Press the [-] key several times, to bring up the display on the left.
Press the [>] key.



Press the [Enter] key.

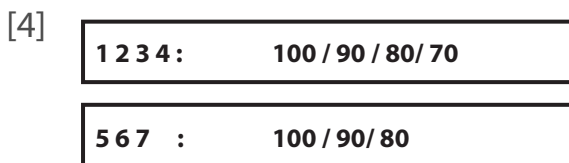

Press the [-] key to change the display.
• The ink level is displayed from 0% to 100%.

• 4-color setting

1	M1 (Magenta)	2	M2 (Magenta)	3	C1 (Cyan)	4	C2 (Cyan)
5	Cl (Cleaner)	6	K (Black)	7	Y (Yellow)		

• 5-color setting

1	K (Black)	2	M (Magenta)	3	C (Cyan)	4	Y (Yellow)
5	Cl1 (Cleaner)	6	Cl2 (Cleaner)	7	Wh (White)		

Note

If it is blinking at 10%, smartchip recovery is being performed on the corresponding ink cartridge.

["Smartchip recovery" P. 145](#)

When it becomes time to replace ink

When the ink level becomes low, the error LED of the operation panel flashes and a buzzer sounds.

Steps

[1]

[2] Ink Low

Press the [Enter] key.

- The buzzer stops.
- In the figure to the left, the slot 2 ink cartridge (ink bag) is nearing replacement.

[2] Prepare the replacement ink.



Note

Sleep mode continues after stopping the buzzer.

Replacing ink

When a cartridge or pack is out of ink, the error LED on the operation panel flashes with beep sounds. The printer pauses printing. After replacing with the new ink, it resume printing.



Important!

- **Do not replace ink when the power of this product is OFF. Ink level cannot be detected correctly.**
- **If ink is moved from cold to warm place, leave it at least three hours.**



WARNING



Leave ink bags away from fire or high temperature objects.

It may cause fire.



CAUTION



Wear protective equipment (gloves, goggles or eye protection, protective mask, protective clothing) when handling ink.

Be cautious that ink does not get into your eye or make a contact with your skin.

When ink gets into your eye or make a contact with your skin, wash with water immediately. If left as it is, it may cause red eye or light inflammation. If it is necessary, please see your doctor immediately.



Steps

1. Removing the High capacity ink pack adapter

[1]

[4 6] Ink End

Press the [Enter] key.

- The buzzer stops.
- In the icons shown on the left, the Slot 4 and 6 ink bags need replacing.

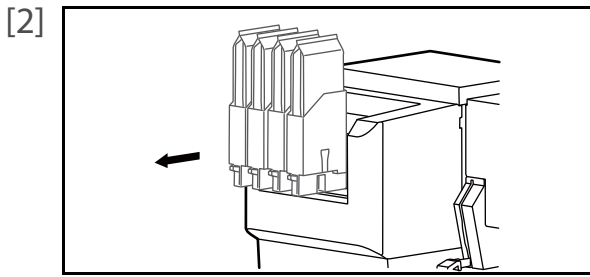

Wear the plastic gloves, and then remove High capacity ink pack adapters from the ink cartridge slots.

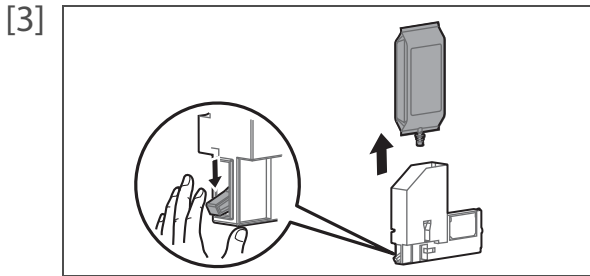

Lower the lock lever on the High capacity ink pack adapter and detach the empty ink bag.



Note

Place the used ink bag in a plastic bag or the like and dispose of it in accordance with local ordinances and municipal instructions.

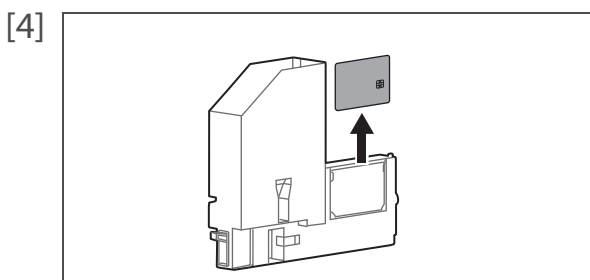

Remove the S/C card from the High capacity ink pack adapter.

2. Attaching ink bag

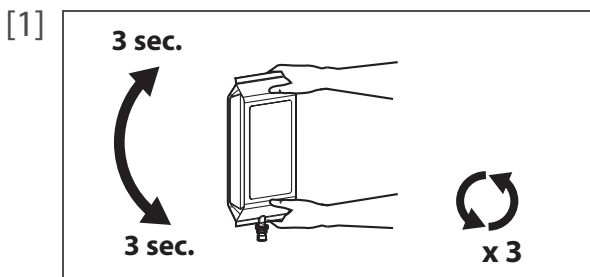

Prepare the new ink bag, and agitate it as instructed below.

- Turn the ink plug upward and wait for three seconds.
- Next, turn the ink plug downward and wait for three seconds.
- Repeat that three times.



Note

When replacing varnish ink, you do not have to agitate it.

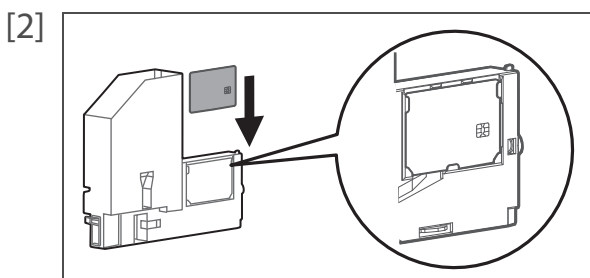

Slide the S/C card into the tabs of the adapter.

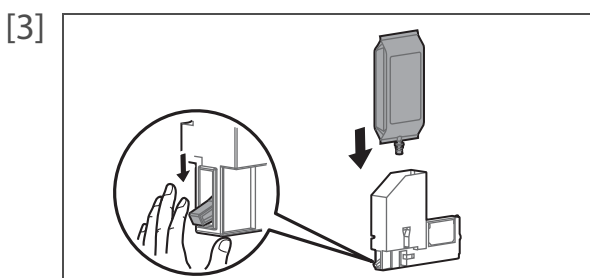

While lowering the lock lever of the High capacity ink pack adapter,

- insert an ink bag.
- Make sure to fully insert the ink bag into the High capacity ink pack adapter.

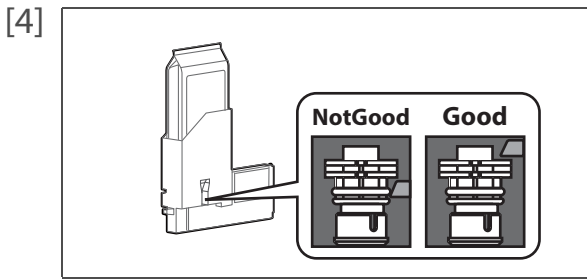

Confirm ink bag is fully seated by checking the lock mechanism is at the top of the ink delivery neck through the observation window, see proper placement in illustration left.

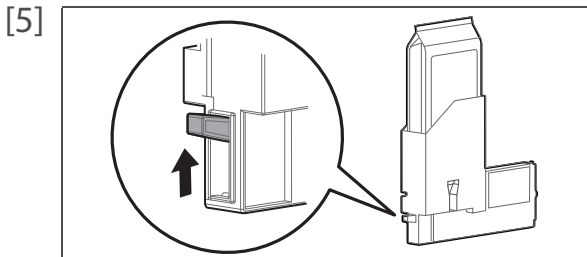

Make sure that the lock lever of the High capacity ink pack adapter is back to its original position.

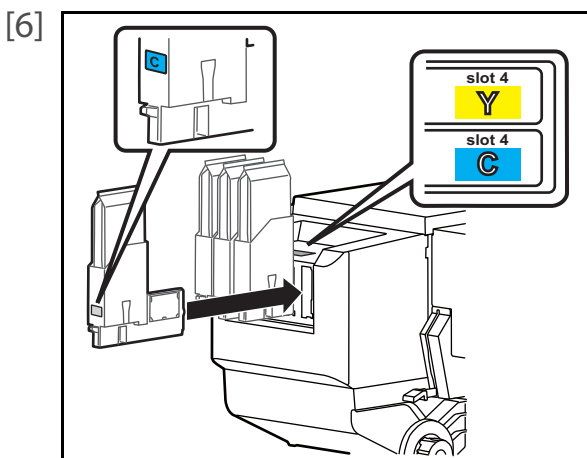

Re-insert the High capacity ink pack adapters into Ink cartridge slots.

- Make sure to match the ink color with the label of this printer.
- Insert all the way to the end.

Important!

Make sure you insert the High capacity ink pack adapters into the original slots. Even when you have the same color ink packs, do not switch and insert them into different slots.

Replacing Adapter's plug for High capacity ink pack adapter

When the plug life runs out, the error LED on the operation panel turns on and a message is displayed. Follow the procedure below to replace the plug.



Press the [Enter] key.

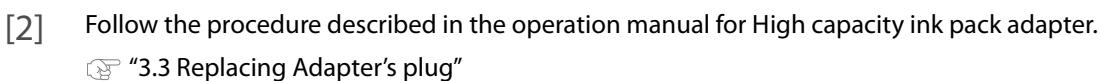

When inserting the replaced adapter, the message on the left will appear.

- Press the [-] key.



Press the [Enter] key.

- The adapter's plug lifetime counter will be reset.

Important!

- **If the adapter's plug is not replaced, do not choose "Yes".**
- **Ink leakage may occur by continuing to use such adapter's plug.**

Emptying waste fluid tank

Emptying waste fluid tank

In the following cases, move the waste fluid in the waste fluid tank into a container to discharge it.

- When Waste fluid tank is more than half full
- When "Empty Waste Ink -> E" is displayed
- When "Full WasteInkTank" is displayed

Display messages

Empty Waste Ink -> E

Empty the waste fluid tank.

- The printer stops initial cleaning. After emptying the tank, press the [Enter] key to resume the cleaning.

Full WasteInkTank

The waste fluid tank has become full. Empty the waste fluid tank immediately.

- Printing or other operation will stop. It will resume when you have transferred the waste fluid.

CAUTION



Wear protective equipment (gloves, goggles or eye protection, protective mask, protective clothing) when handling ink.

Be cautious that ink does not get into your eye or make a contact with your skin.

When ink gets into your eye or make a contact with your skin, wash with water immediately. If left as it is, it may cause red eye or light inflammation. If it is necessary, please see your doctor immediately.



1. Transfer the waste fluid

- [1] Prepare a container to put the waste fluid in.



The capacity of waste fluid tank is 2,000 ml. Make sure to prepare a container that has enough capacity when discharging waste fluid.

- [2] Cover the floor beneath the waste fluid tank using paper you do not need or the like.

- [3] Wear personal protective equipment such as plastic gloves, goggles, protective mask or clothing.

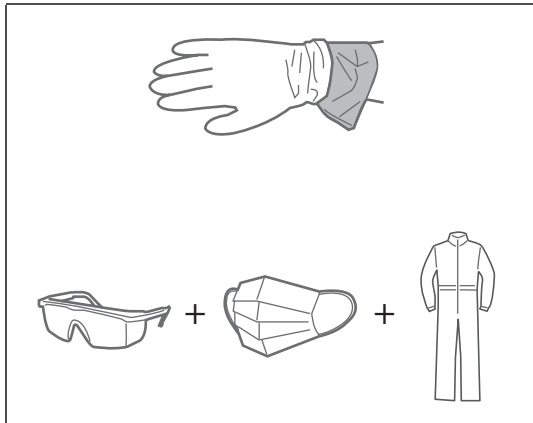

- [4] Press on the absorbent material tray of the waste fluid valve to store it.

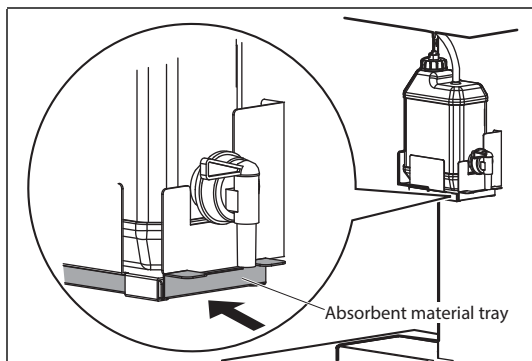

- [5] Open the waste fluid valve, and transfer the waste fluid to the container.

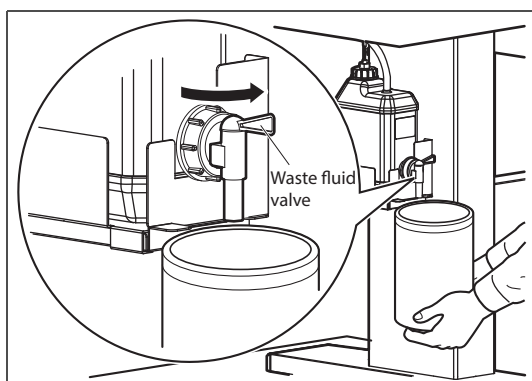

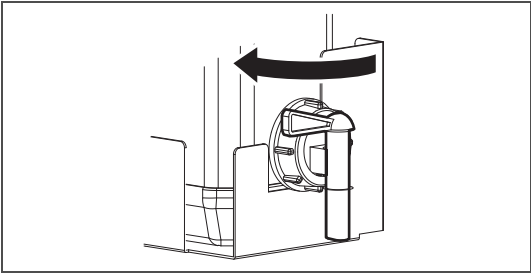
- [6]  After pouring the waste fluid to the empty container, close the waste fluid valve securely.

- [7] Wipe the opening of Waste fluid valve with a cloth, etc.

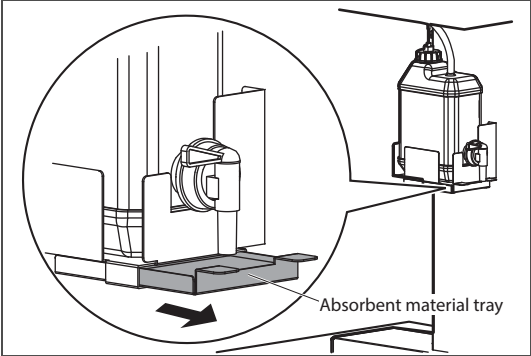
- [8]  Pull out the absorbent material tray.

- [9] Dispose of the waste fluid as an industrial waste product.

 **WARNING**



You are obligated to properly dispose of waste fluid from the printer in compliance with Wastes Disposal and Public Cleansing Act and local ordinances. Delegate disposal to an industrial waste disposal contractor.

Daily Maintenance

Flow of Daily Maintenance

This printer requires daily maintenance.

Follow the steps below to perform daily maintenance after you finish your printing for the day.

- "Perform Daily Maint." is prompted on the operation panel after certain period of time from the previous daily maintenance.
Make sure to perform daily maintenance when prompted.

Important!

If you perform printing all day without entering to sleep mode, make sure to perform daily maintenance once a day.

Failure to perform daily maintenance may affect print quality or result in damage to the printer.

To perform daily maintenance without entering to sleep mode, go to "Mnt.1: Daily Maint." on the operation panel.

 ["Maintenance 1: Daily Maintenance" P. 91](#)

 ["Continuously using printer after daily maintenance" P. 118](#)

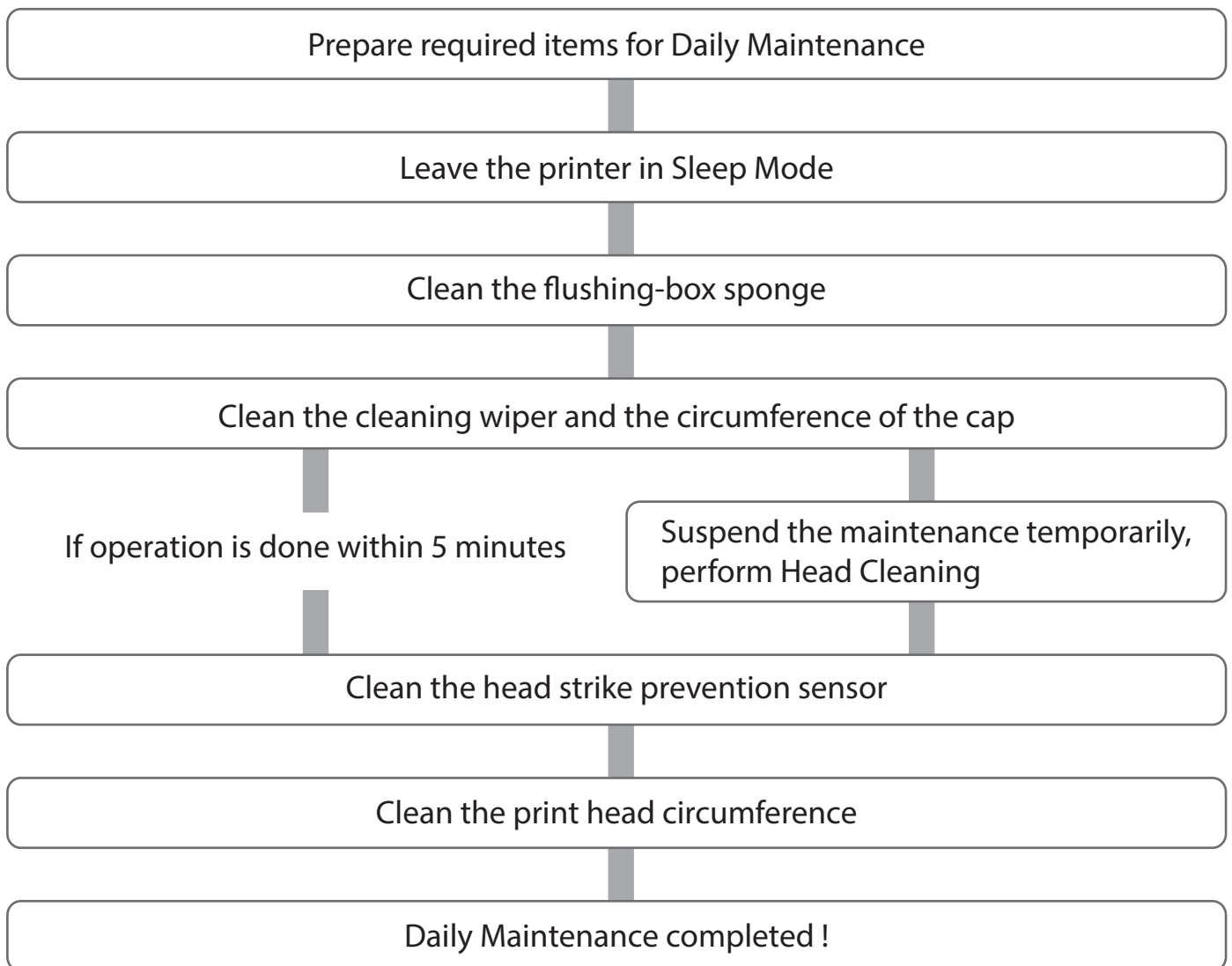

Preparing for Daily Maintenance

Required Items

[1] Prepare the following items to perform daily maintenance.

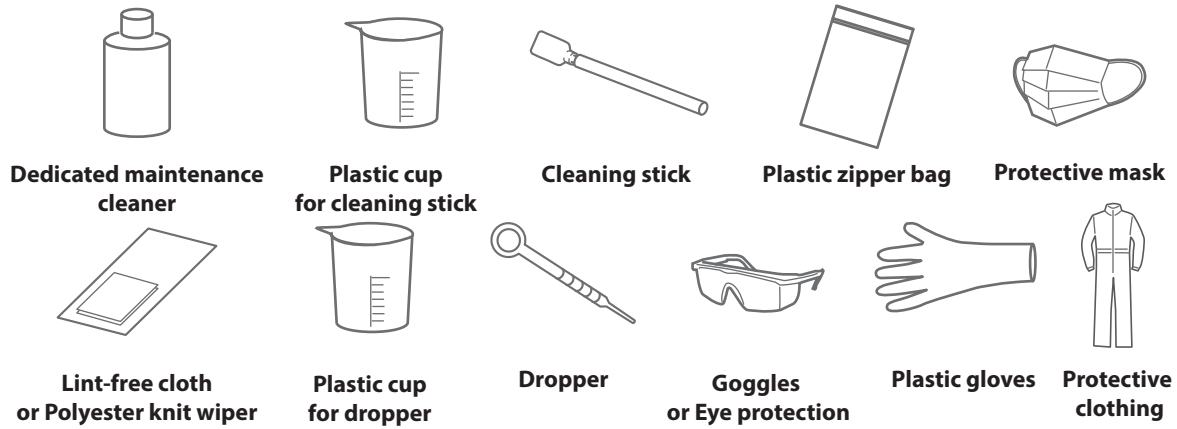

Important!

- Use a paper towel supplied with the printer or optional polyester knit wiper. **DO NOT** use a tissue. Lints or flakes on tissue may cause damage to the print head.
- **DO NOT** use non-dedicated maintenance cleaner.
- If you cannot suck up maintenance cleaner directly from the maintenance cleaner bottle using the dropper, use one of the plastic cup to pour the cleaner.
If the maintenance cleaner still remains in the plastic cup, put a plastic bag or wrap over the cup to keep out dust.
- If you want to purchase the optional maintenance cleaner, contact your local Mutoh dealer or nearest Mutoh sales office.

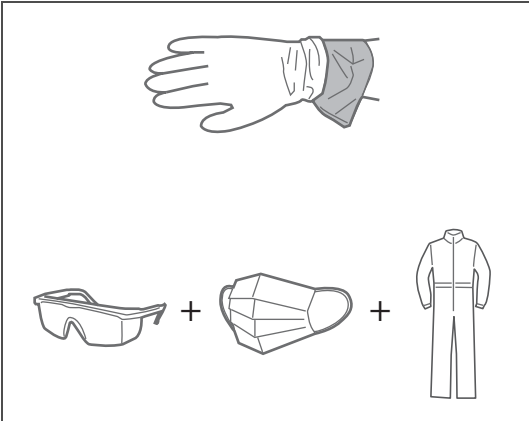
[2] 

Wear personal protective equipment such as plastic gloves, goggles, protective mask or clothing.

CAUTION



Be cautious that ink does not get into your eye or make a contact with your skin. When ink gets into your eye or make a contact with your skin, wash with water immediately. If left as it is, it may cause red eye or light inflammation. If it is necessary, please see your doctor immediately. Wear personal protective equipment (supplied gloves or solvent-resistant gloves, goggles or protective eyewear, protective mask, protective clothing) to avoid skin contact with ink.



Entering to sleep mode

[1]

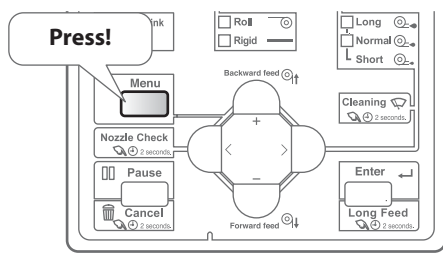

Press the [Menu] key.

[2]

Menu1: Sleep Mode >

Press the [>] key.

[3]

SleepMode: Start

Press the [Enter] key.

[4]

Start Sleep Mode?

Press the [Enter] key.

[5]

Daily Maint. : Start

Press the [Enter] key.

[6]

Wash Exe ? : Yes

When using 4-color set, select whether or not to clean the cleaning wiper and flushing box with the cleaner.

Wash Exe ? : No

- "Wash Exe? No": Cleaning is not performed automatically.
- "Wash Exe? Yes": Cleaning is performed automatically.

Note

Note that the ink inside Print head is discharged by the cleaner; therefore some ink will be used.

[7]

Cleaning ** %

The printer automatically performs the "Short" cleaning.

Wait for a while

- The carriage and cleaning wiper move to gain access to daily maintenance.

[8]

Daily Maint. : End

The message on the left will appear.

- You can start daily maintenance.

Important!

- **Make sure to complete this maintenance within 5 minutes while the printer is in Daily maintenance state. If it takes longer, the stick can dry causing damage to the print head.**
- **If maintenance is likely to take more than 5 minutes, suspend it and perform head cleaning before resuming the maintenance.**

Performing Daily Maintenance

Important!

When performing daily maintenance, check the points below:

- Do not touch the cleaning wiper and the capping unit with your hands.
If oil from your hands gets on those parts, this cleaning may not be performed properly.
- Do not touch the print head surface with fingers or a cleaning stick.
It can cause damage to the print head.
- Always use a cleaning stick dampened with the dedicated maintenance cleaner in the plastic cup.
DO NOT use non-dedicated maintenance cleaner. It may cause nozzle clogging.
- DO NOT touch the tip of the cleaning sticks with your finger.
If finger oil gets on the stick, it will damage the print head.

1. How to clean the flushing-box sponge

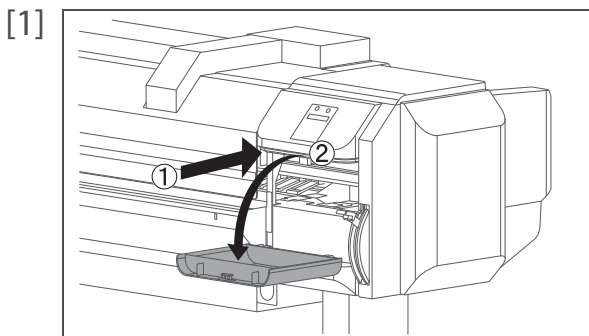

Open the maintenance cover on the right.

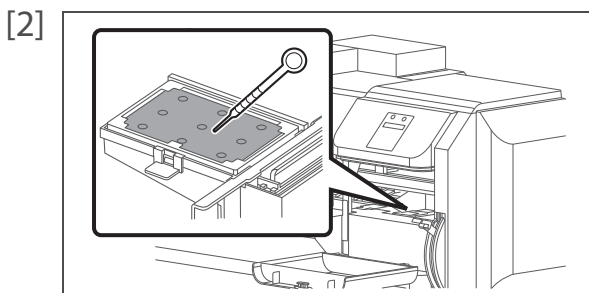

Use the dropper to moisten the flushing-box sponge with maintenance cleaner.

- Amount used: 3.0 ml

Note

Do NOT use the maintenance cleaner in the plastic cup that the cleaning stick is submerged.

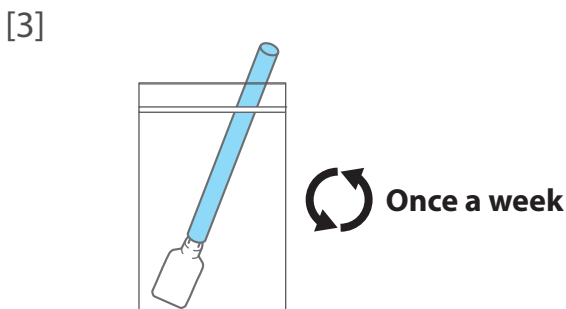

Prepare a cleaning stick for cleaning the flushing-box sponge.

Important!

The cleaning stick can be used for 1 week.

Change the cleaning stick once a week, or when the ink on the stick cannot be removed.

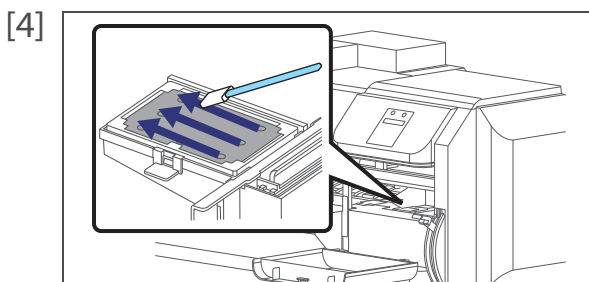

Use the cleaning stick to clean the whole area of sponge.

If you cannot remove ink clumps using the cleaning stick, replace the flushing-box sponge.

 **"Replacing absorption material for the flushing box" P. 123**

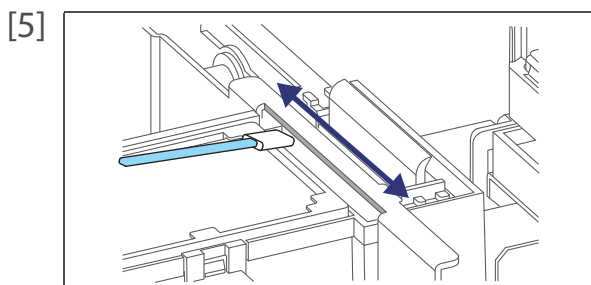
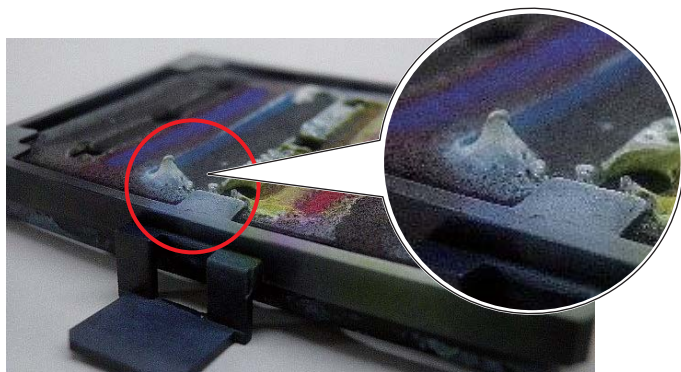

Clean off the ink on the left edge of the part, located between the flushing box and cleaning wiper.

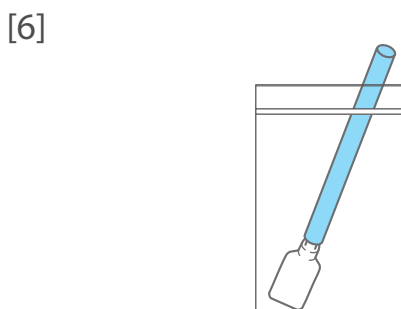

After the cleaning is done, put the cleaning stick in the plastic zipper bag and close the zipper to store.



Note

Make sure to close the zipper firmly to avoid dust in the bag.

2. How to clean the cleaning wiper and capping unit



Prepare another cleaning stick to clean the cleaning wiper and around the capping unit.

- Pour 30 ml of dedicated maintenance cleaner into the plastic cup and dip the foam tip of the cleaning stick in it.

Important!

- **The cleaning stick submerged in the plastic cup can be used for 1 week. Change the cleaning stick once a week, or when the ink on the stick cannot be removed.**
- **Make sure to change the maintenance cleaner once a week.**
- **If the cleaning stick gets dirty while cleaning, submerge the foam tip of the stick into the maintenance cleaner in the cup.**

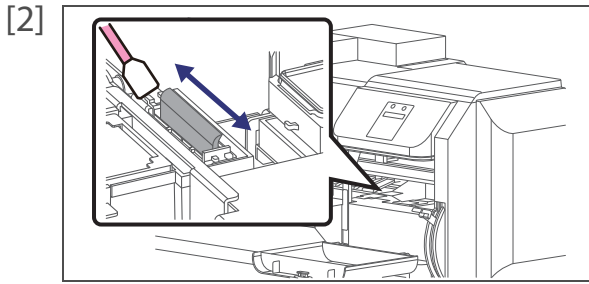

Wipe the cleaning wiper with a cleaning stick.

- Wipe the left side surface of cleaning wiper going back and forth.

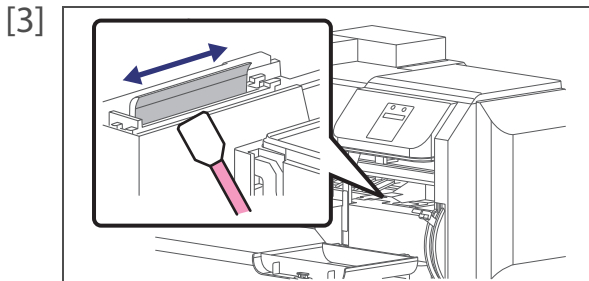

Wipe the right side surface of cleaning wiper going back and forth.

[4] Check that the cleaning wiper and the area around are clean.

Left side of the cleaning wiper

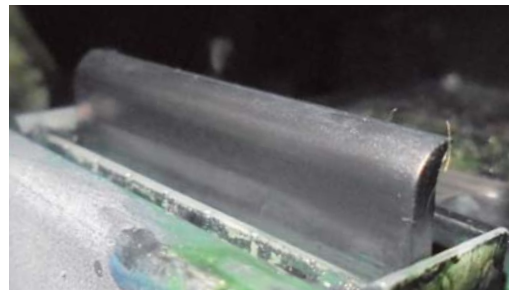

Right side of the cleaning wiper

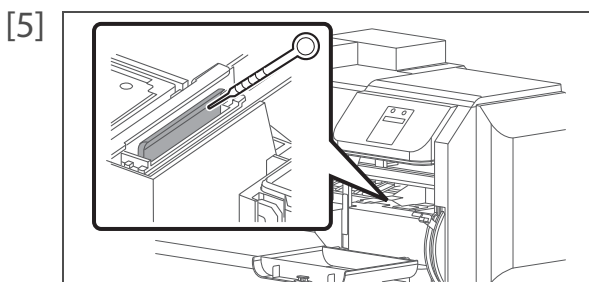
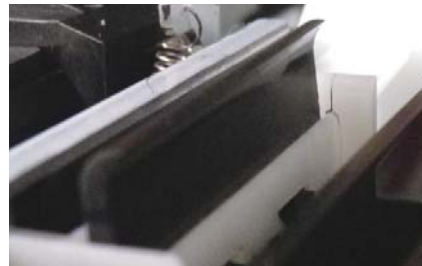
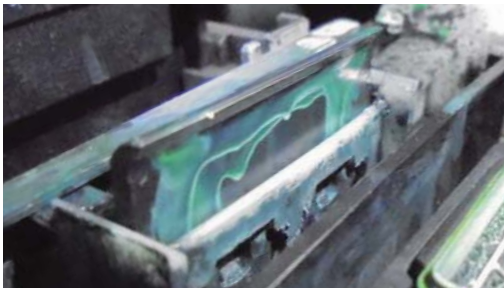

Use a dropper to moisten the cleaning wiper with maintenance cleaner.

- Amount used: 5.0 ml

 **Note**

Do NOT use the maintenance cleaner in the plastic cup that the cleaning stick is submerged.

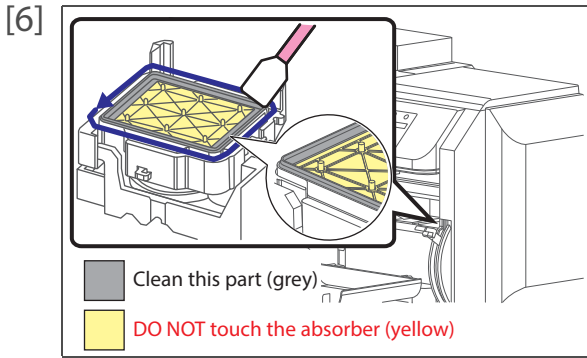

Use the cleaning stick to clean around the rubber part of the capping unit to remove the ink deposits and dust.

[7] Check that the capping unit and the area around are clean.

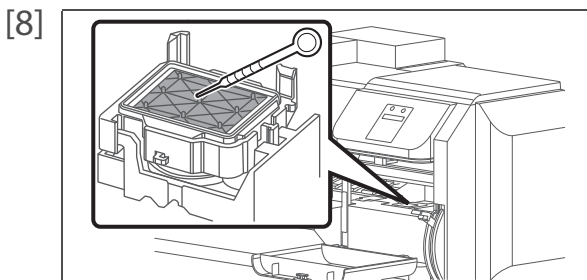
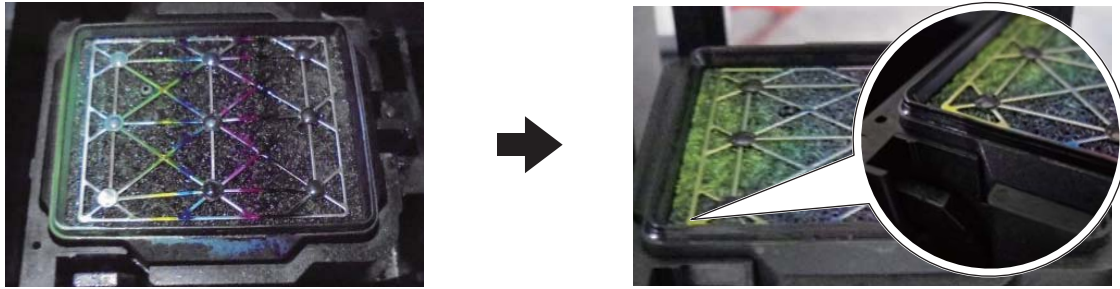

Use the dropper to moisten the absorber of the capping unit with maintenance cleaner.

- Amount used: 1.5 ml

Note

Do NOT use the maintenance cleaner in the plastic cup that the cleaning stick is submerged.

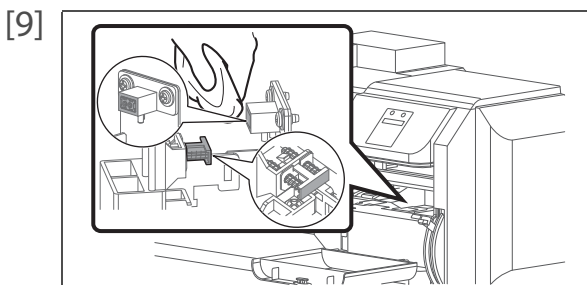

Moisten the lint-free cloth with maintenance cleaner and clean the air valve surface to remove the ink deposits.

Note

Wear plastic groves to avoid contact with maintenance cleaner.

[10] Next clean the head strike prevention sensor.

["How to clean the head strike prevention sensor" P. 115](#)

Important!

- Standard cleaning time should be within 5 minutes.
- If maintenance is likely to take more than 5 minutes, suspend it and perform head cleaning before resuming the maintenance.

3. How to clean the head strike prevention sensor

[1]

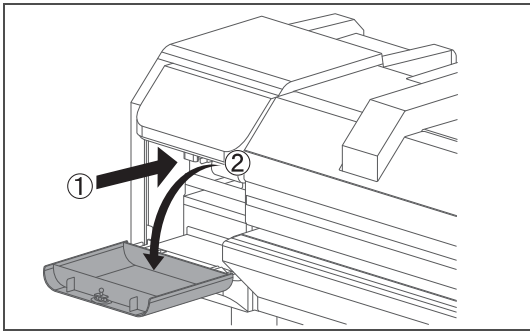

Open the maintenance cover on the left.

[2]

Check if ink stains on the bottom of the sensor.

- If stains, use the paper towel moistened with a few drops of cleaning fluid and gently wipe off the ink on the sensor.

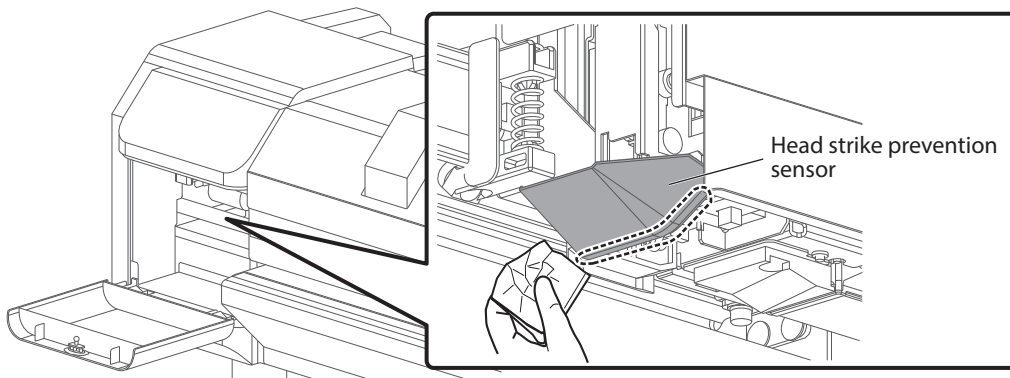

Important!

- **Always wear protective gloves to avoid direct contact with cleaning fluid.**
- **To avoid damage to the sensor while cleaning, use the other hand to hold it to stabilize.**
- **While cleaning, do not apply too much pressure. It may damage the sensor.**

[3]

Next clean the print head circumference.

 ["How to clean around the print head" P. 116](#)

4. How to clean around the print head

- [1] Look at the bottom side of the carriage and check if dusts and ink lump are adhered.
- Print head circumference (silver metal part)
 - Print head guide part (black plastic part)

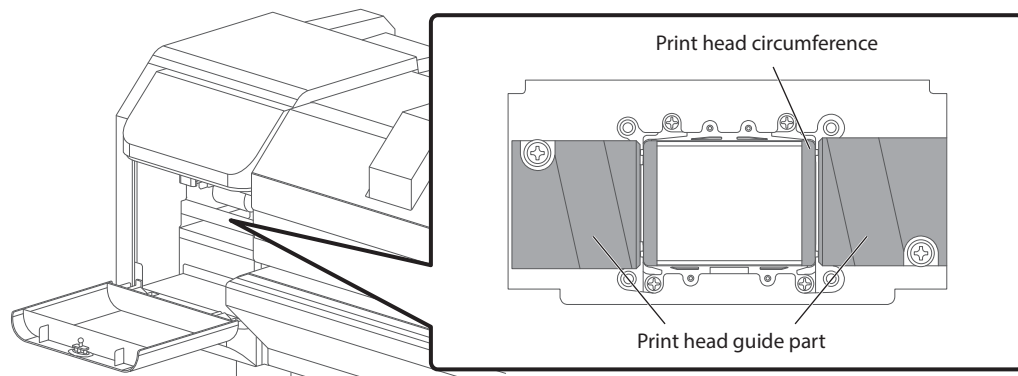

- [2] Use the cleaning stick to remove the ink deposits or dust on the bottom of the carriage.

 Clean this part (grey)

 **DO NOT touch the surface of a print head (yellow)**

Surface around print head (silver metal part)

Print head guide (black plastic part)

※Clean the part between the print head and print head guide.

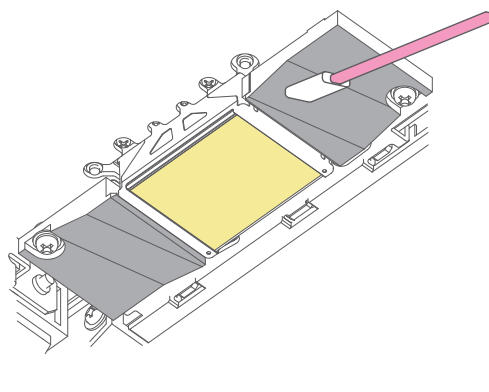
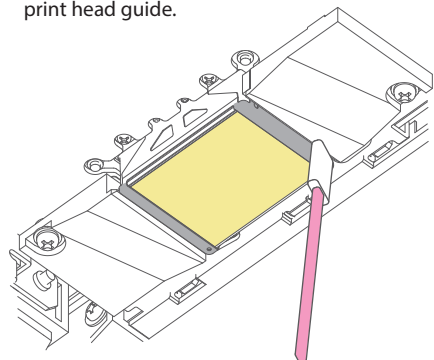

Important!

- **Do not touch the platen or media guide. The temperature may be high.**
- **If maintenance cleaner is splashed onto the printer, use a lint-free cloth to wipe it off.**

[3] Check that the area around the print head is clean.

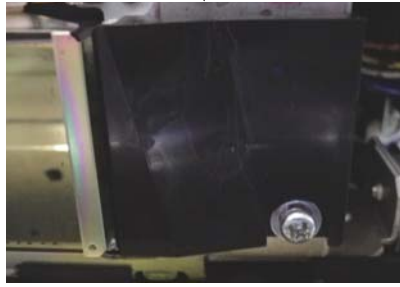

[4] Close the maintenance cover on the right.

[5]

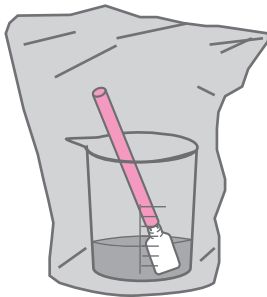

After cleaning, leave the cleaning stick dipped in dedicated maintenance cleaner.

Important!

- Using plastic bag or wrap, cover the plastic cup with dedicated maintenance cleaner inside to keep out dust.
- Check that the lid of the maintenance cleaner is shut properly and store it.

[6] Next finish the daily maintenance.

5. Finishing daily maintenance

[1]



Press the [Enter] key.

- The printer automatically enters to sleep mode.

[2]

Use a paper towel to wipe the maintenance cleaner off the dropper.

[3]

Now the daily maintenance is complete.

Continuously using printer after daily maintenance

In following cases, clean the daily maintenance parts.

- If faint print or dot missing still persists even after head cleaning has been performed.
- If you perform printing all day without entering to sleep mode and you need to perform daily maintenance.

Preparation:

See "[Preparing for Daily Maintenance](#)" P. 109 to prepare items required for the maintenance.



Important!

If you want to continuously use the printer after this maintenance, follow the steps below.

If you will not use the printer after this maintenance, enter to sleep mode and then perform maintenance.

"[Daily Maintenance](#)" P. 108

1. Putting the printer into the Daily maintenance mode

[1]

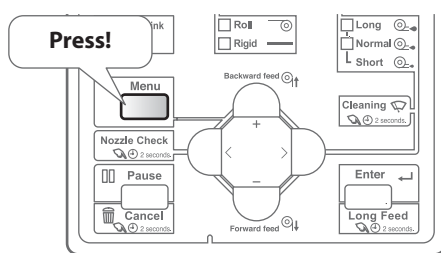

Press the [Menu] key.

[2]



The message on the left will appear.

[3]



Press the [-] key several times, to bring up the display on the left.

- Press the [>] key.

[4]



Press the [Enter] key.

[5]



Press the [Enter] key.

[6]



When using 4-color set, select whether or not to clean the cleaning wiper and flushing box with the cleaner.

- "Wash Exe? No": Cleaning is not performed automatically.
- "Wash Exe? Yes": Cleaning is performed automatically.



Note

Note that the ink inside Print head is discharged by the cleaner; therefore some ink will be used.

[7]

Cleaning	** %
----------	------

 The printer automatically performs the "Short" cleaning.

Wait for a while

 • The carriage and cleaning wiper move to gain access to daily maintenance.

[8]

Daily Maint. :	End
----------------	-----

 The message on the left will appear.
• You can start daily maintenance.

2. Cleaning daily maintenance parts

The maintenance procedure and parts to be cleaned are the same as ["Daily Maintenance" P. 108](#). Follow the steps described in ["Performing Daily Maintenance" P. 111](#) to clean each part.

- ["How to clean the flushing-box sponge" P. 111](#)
- ["How to clean the cleaning wiper and capping unit" P. 112](#)
- ["How to clean the head strike prevention sensor" P. 115](#)
- ["How to clean around the print head" P. 116](#)

Important!

- **Make sure to complete this maintenance within 5 minutes while the printer is in Daily maintenance state.**
- **If maintenance is likely to take more than 5 minutes, suspend it and perform head cleaning before resuming the maintenance.**

3. Finishing maintenance

[1] Close the front cover and the maintenance cover.

[2]

Daily Maint. :	End
----------------	-----

 Press the [Enter] key.

[3] Use a paper towel to wipe the maintenance cleaner off the dropper.

[4] Now the maintenance is complete.



Cleaning each part

To use this product always in its best condition, please clean periodically.

Head cleaning

When nozzle missing is found in nozzle check, conduct head cleaning. Head cleaning consumes ink.

There are several cleaning modes in this product. Please use them accordingly based on your usage condition.

Short cleaning	Consumes less ink than Normal cleaning.
Normal cleaning	Conduct nozzle check before and after printing, and use when nozzle missing is found.
Long cleaning	Consumes more ink than Normal cleaning. When nozzle missing still occurs after Normal cleaning, conduct Long cleaning.
Little Charge	Though much better cleaning results can be expected than Long cleaning, it consumes a large amount of ink. *This mode cannot be selected via the "Cleaning" key. Select it from the Cleaning submenu in the Panel Setting Menus.  "Menu 5: Cleaning" P. 89
Initial Charge	Gives a rather higher cleaning effect than "LittleCharge", but also consumes rather more ink. *This mode cannot be selected via the "Cleaning" key. Select it from the Cleaning submenu in the Panel Setting Menus.  "Menu 5: Cleaning" P. 89

Important!

Comply strictly with the following when you performing "Little Charge" or "Initial Charge": If charging is interrupted, ink will be lost when charging is resumed.

- **Do not open the Front cover or the Maintenance cover.**
- **Do not use ink bags that have little ink remaining.**

Steps for head cleaning

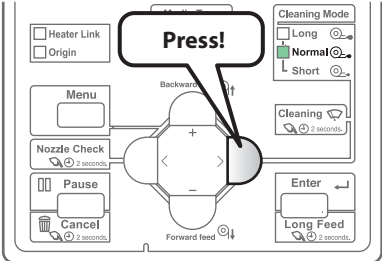
- [1]
- 
- Use the [Cleaning] key to select a cleaning mode.
- The “Cleaning Mode” indicators will change each time the key is pressed.
- Note**
- You can alternatively do this via the MSM's remote panel.
 - The “Cleaning Mode” indicators will change as shown below.

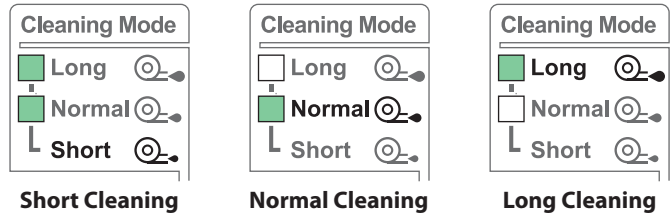

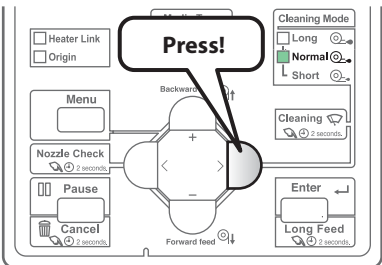
- [2]
- 
- Press the [Cleaning] key for more than two seconds.
- Cleaning will start.

- [3] Perform Nozzle Check.
- If there is still nozzle missing, repeat cleaning and nozzle check.
-  ["Steps for head cleaning" P. 121](#)

Note

- When nozzle missing remains even after repeating normal cleaning several times, perform Long cleaning.
- When nozzle missing remains even after repeating Long cleaning several times, conduct **"Continuously using printer after daily maintenance" P. 118.**
- If the nozzle missing still is not rectified, perform “LittleCharge” via the Cleaning menu in the Panel Setting Menus.

Inside cleaning

Cleaning period:

- Monthly
- When dust or ink stains are visible

Preparation:

- Soft brush
- Soft cloth

Steps

[1] Remove the media.

[2] Open the front cover.

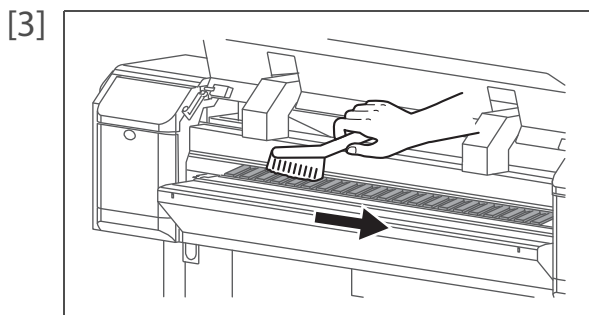

Brush off dusts on the pressurizing rollers with a soft brush.



Do not blow off dusts inside the product with a gas duster.

Dust can attach to moving parts, causing abnormal sound or malfunctions.

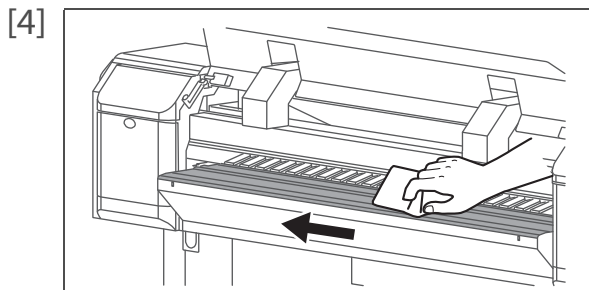

Use a wet, tightly-wrung soft cloth to clean the media guide.

[5] Close the front cover.

Replacing consumable parts

Replacing absorption material for the flushing box

The flushing box is a part that keeps receiving ink discharged from the print head. Please replace the absorption material for the flushing box periodically. If used without replacing, it can cause damage to the print head.

Replacing period:

- When the flushing-box frame was deformed.
- When ink clumps have accumulated on the flushing-box sponges beyond the flushing-box frame.

Preparation:

- Wear protective equipment (gloves, goggles or eye protection, protective mask, protective clothing)
- Absorption material for the flushing box
- Paper you can get dirty (paper which ink will not bleed through)

CAUTION



Wear protective equipment (gloves, goggles or eye protection, protective mask, protective clothing) when handling ink.

Be cautious that ink does not get into your eye or make a contact with your skin.

When ink gets into your eye or make a contact with your skin, wash with water immediately. If left as it is, it may cause red eye or light inflammation. If it is necessary, please see your doctor immediately.



1. Checking steps

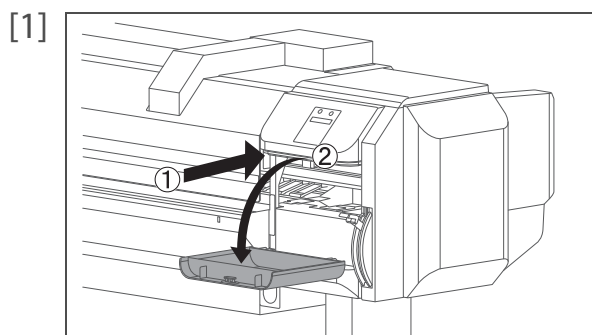

Open the maintenance cover on the right.

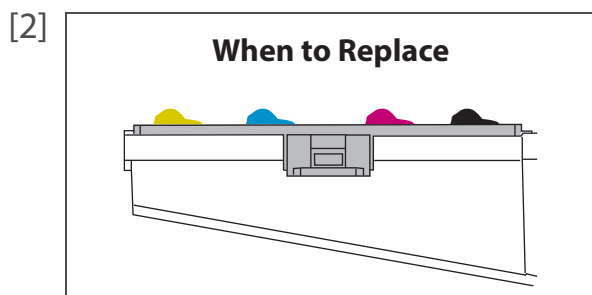

Check the absorption material for the flushing box.

- When the flushing-box frame was deformed or there are lumps of ink rise from the frame of the flushing box, it is time to replace.
- Close the maintenance cover.

2. Moving print head out of capping station

[1]

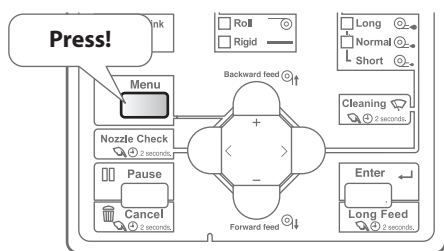

Press the [Menu] key.

[2]

Menu1: Sleep Mode >

The message on the left will appear.

[3]

Menu7: Maintenance >

Press the [-] key several times, to bring up the display on the left.

- Press the [>] key.

[4]

Mnt.1 : Daily Maint.

The message on the left will appear.

[5]

Mnt. 3 : Cap Out

Press the [-] key several times, to bring up the display on the left.

- Press the [Enter] key.

[6]

Cap Out : Start

Press the [Enter] key.

Wait for a while

- The carriage moves to the center of the printer.
- The cleaning wiper moves upward.

[7]

Cap Out : End

The message on the left will appear.

- You can start replacement.

3. Replacing steps

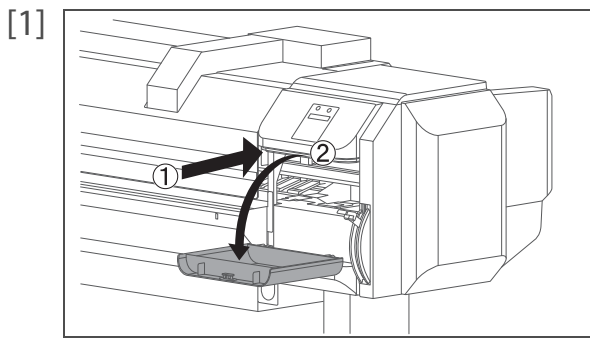

Open the maintenance cover on the right.

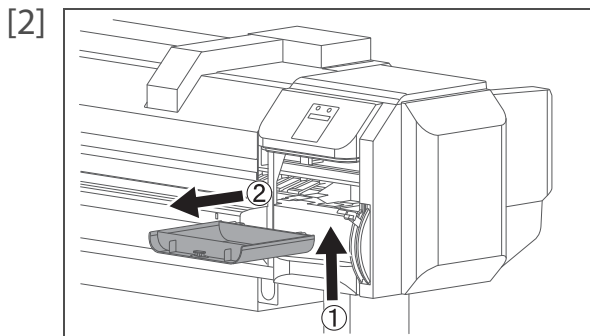

Detach the maintenance cover.

[3] Cover the platen with the paper you can get dirty.

Important!

**Ink may drip from the absorption material for the flushing box.
We recommend covering the floor with paper as well.**

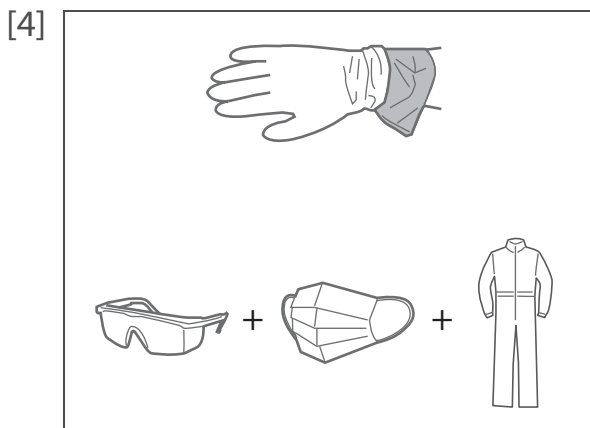

Wear personal protective equipment such as plastic gloves, goggles, protective mask or clothing.

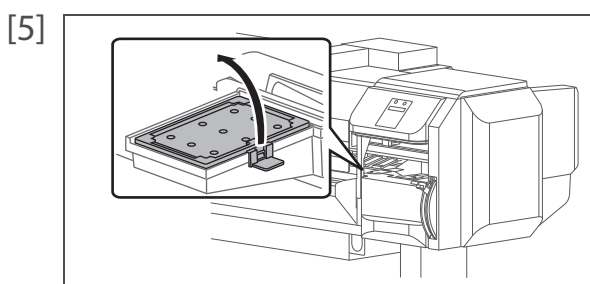

Pull the tab up of the absorption material for the flushing box, and release the hook.
Then remove the absorption material for the flushing box.

Important!

When removing the absorption material for the flushing box, be cautious of ink drops.

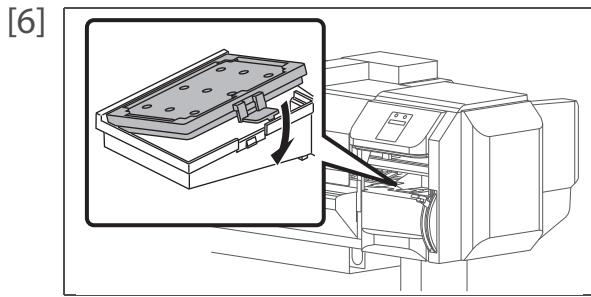

Attach new absorption material for the flushing box.

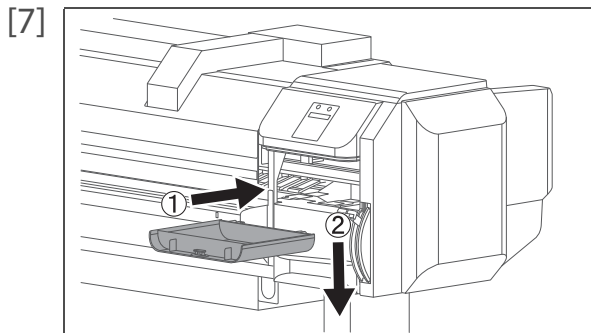

Attach the maintenance cover.

[8] Close the maintenance cover.



Press the [Enter] key.



The message on the left will appear.

- That ends the procedure.

Replacing the cleaning wiper

The cleaning wiper is an essential part to make printing consistent. Please replace it periodically.

Replacing period:

- Approx. every six months

Preparation

- Wear protective equipment (gloves, goggles or eye protection, protective mask, protective clothing)
- Absorption material for the flushing box
- Paper you can get dirty (paper which ink will not bleed through)

CAUTION



Wear protective equipment (gloves, goggles or eye protection, protective mask, protective clothing) when handling ink.

Be cautious that ink does not get into your eye or make a contact with your skin.

When ink gets into your eye or make a contact with your skin, wash with water immediately. If left as it is, it may cause red eye or light inflammation. If it is necessary, please see your doctor immediately.



Replacing Steps

- [1] Move the print head out of capping station.

 ["Moving print head out of capping station" P. 124](#)

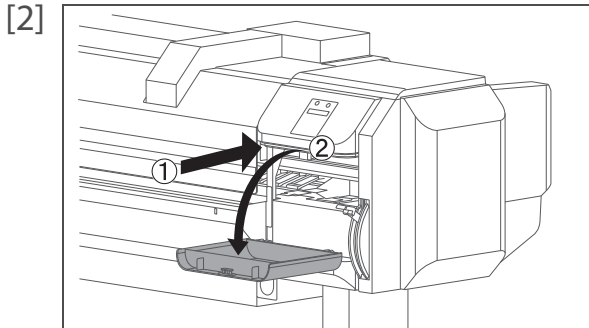

Open the maintenance cover on the right.

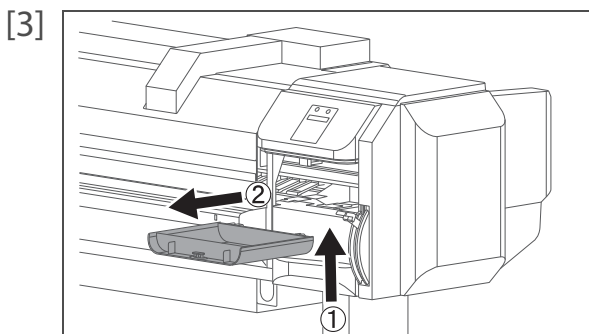

Detach the maintenance cover.

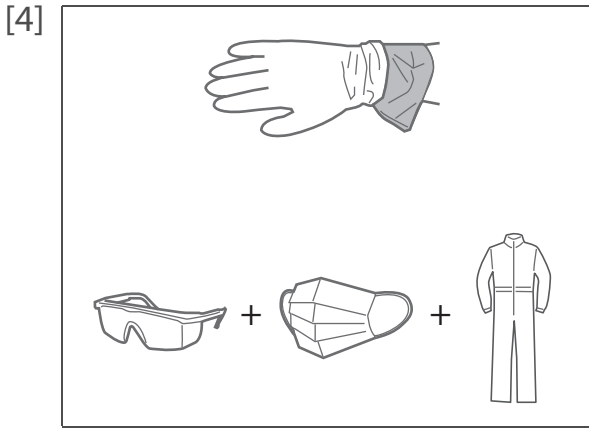

Wear personal protective equipment such as plastic gloves, goggles, protective mask or clothing.

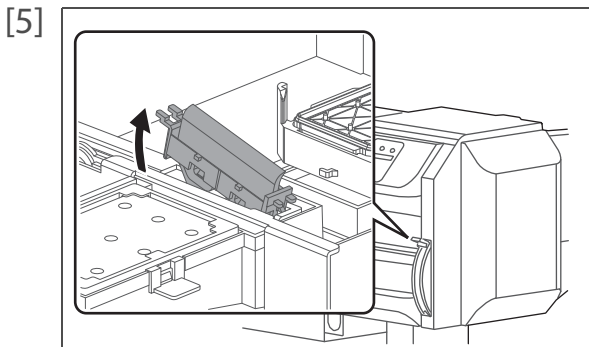

Remove the cleaning wiper.

- Lift the cleaning wiper hook and release the hook. Then, remove the cleaning wiper.

 **Important!**

When removing the cleaning wiper, be cautious of ink drops.

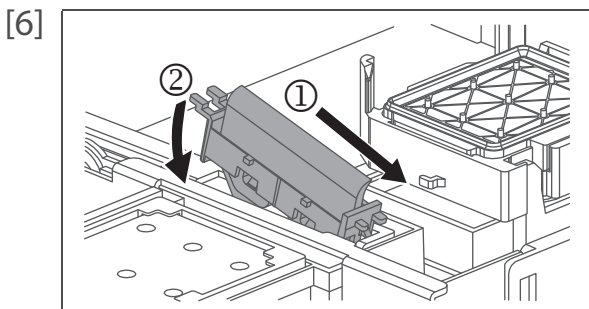

Follow the steps below to install new cleaning wiper.

- Slide the front side of the new cleaning wiper into its slot.
- Press the wiper hook down until it clicks into place.

 **Important!**

Do NOT touch the cleaning wiper rubber with your bare hand. If finger oil gets on the rubber, it will damage the print head.

[7] Attach the maintenance cover, and then close it.



Press the [Enter] key.



The message on the left will appear.

- That ends the procedure.

Moving or transporting the printer

This section describes how to move or transport the printer.

Moving the printer

This section describes how to move the printer.

Important!

- **When moving the printer, make sure to maintain a horizontal position.**
- **Do not tilt, set against something or place this product upside down.**
Otherwise the ink may leak or the handling mentioned above may cause abnormality.
- **When moving this printer, always empty the waste ink tank even moving short distance.**
If ink splashes inside the waste ink tank while being moved, it can cause damage.

1. Preparation before moving

[1] Turn OFF the printer.

 ["Turning the power OFF" P. 29](#)

[2] Dispose of waste fluid.



 ["Emptying waste fluid tank" P. 105](#)

[3] Remove all the cables, such as Power cord set.

[4]  Loosen the four adjusters of Stand as shown in the left.

[5] Move the printer.

2. Reinstalling

- [1] Select a suitable place for installation.
 [Startup Guide](#)
- [2] Move and install the printer to the location.
- [3] Attach Cables, such as Power cord set.
- [4] Perform Nozzle check, and then confirm that there is no clogging in Print head.
 ["Nozzle check steps" P. 43](#)
- [5] Perform print quality adjustment.
 ["Print quality adjustment steps" P. 47](#)

Transporting the printer

When transporting the printer, make sure to pack it in the same condition as purchased, using protective and packing materials to protect the printer from vibration and shocks.



When transporting the printer, consult the MUTOH product dealer at your point of purchase.

Long Storage and Initial Charge

If not using the printer for a long period of time

If you will not use this product for a long period of time (2 weeks or longer), perform the “Long Storage” procedure.



Note

If the period of time you will not use this device is within 2 weeks, you can store it in sleep mode.

["Starting Sleep Mode" P. 31](#)

The procedures of Long Storage is as follows.

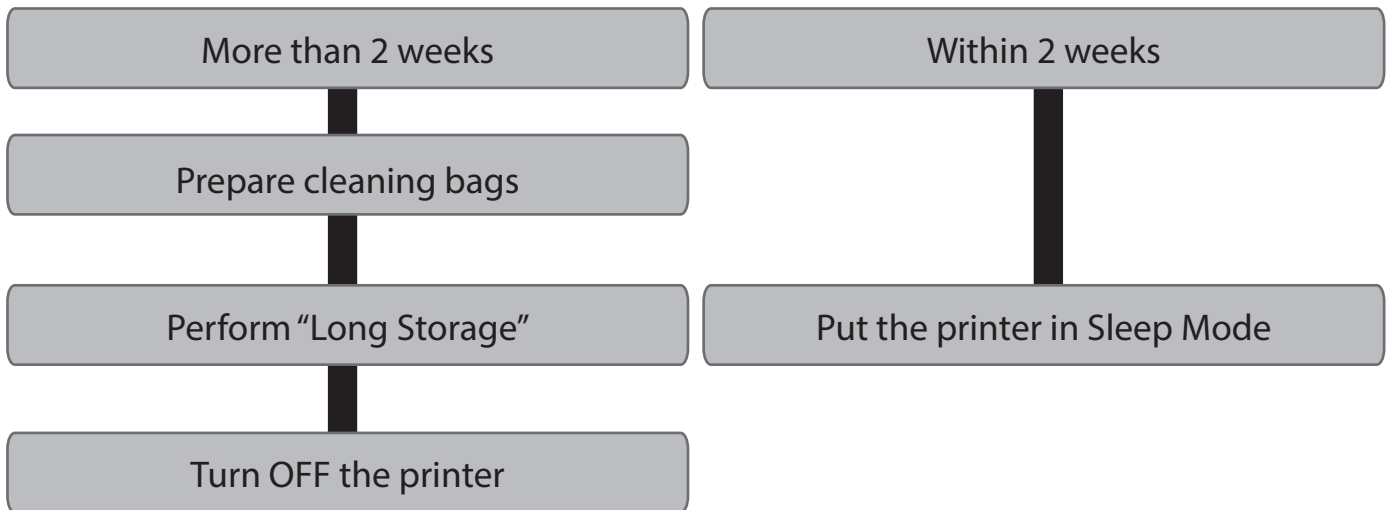

Important!

Be sure to perform daily maintenance before turning the printer off.

If you turn the power off without performing daily maintenance, the nozzle may become clogged.

Performing Long Storage

Required item:

- Cleaning bags (7 bags)

1. Steps for discharging ink

[1]

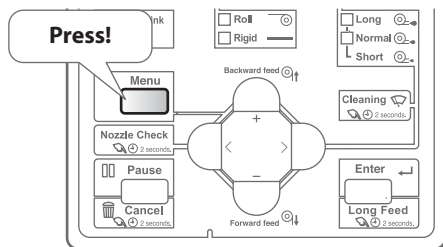

Press the [Menu] key.

[2]

Menu1: Sleep Mode >

The message on the left will appear.

[3]

Menu7: Maintenance >

Press the [-] key several times, to bring up the display on the left.

- Press the [>] key.

[4]

Mnt.1 : Daily Maint.

The message on the left will appear.

[5]

Mnt. 2 : Long Storage

Press the [-] key, to bring up the display on the left.

- Press the [Enter] key.

[6]

Long Storage : Start

Press the [Enter] key.

[7]

Remove Cartridges

When the message on the left appears, remove all High capacity ink pack adapters from the ink cartridge slots.

[8]

Empty WasteInk - > E

When the message on the left appears, transfer the waste fluid into a container.

 ["Emptying waste fluid tank" P. 105](#)

- Press the [Enter] key.

2. Steps for head cleaning

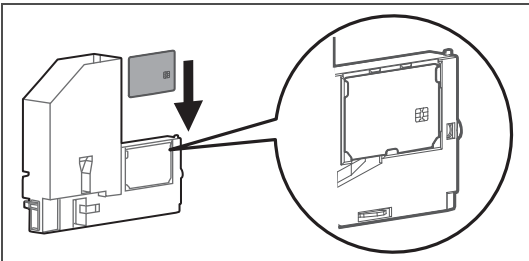
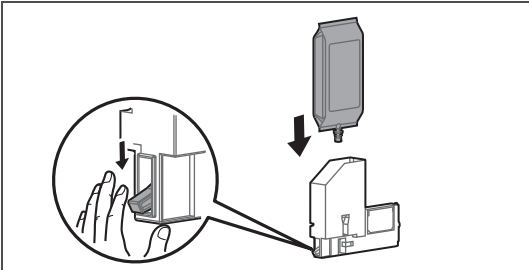
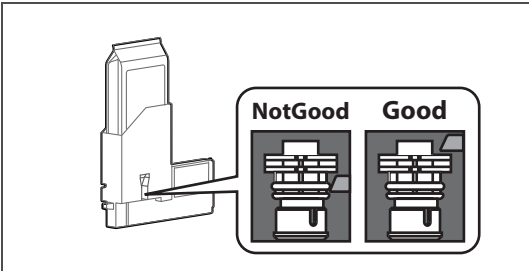
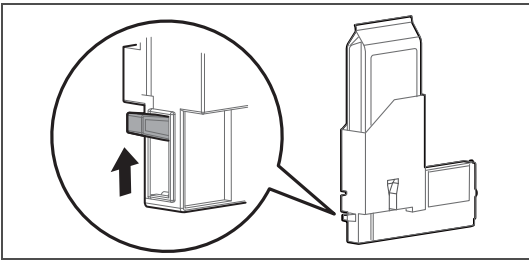
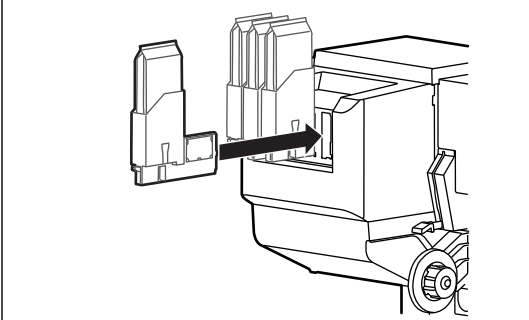
- [1] **Insert CleaningCart.** The message on the left will appear.
- [2]  Slide the smart chip card into the tab on the High capacity ink pack adapter to install it.
- [3]  Lower the lock lever on the High capacity ink pack adapter and insert the cleaning bag.
 - Insert all the way to the end.
- [4]  Confirm that the cleaning bag is inserted all the way and is locked.
- [5]  Confirm that the lock lever on the High capacity ink pack adapter is in its original position.
- [6]  Insert the High capacity ink pack adapter.
 - Firmly insert it all the way in.
- Busy-Washing** The printer starts charging cleaning fluid.

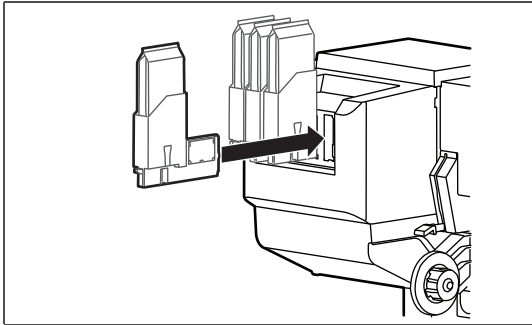
- [7] **Remove Cartridges**
- When the message on the left appears, remove all High capacity ink pack adapters from the ink cartridge slots.
- Busy-Washing**
- The printer starts discharging cleaning fluid.
- [8] **Empty WasteInk - > E**
- When the message on the left appears, transfer the waste fluid into a container.
- ☞ **"Emptying waste fluid tank" P. 105**
- Press the [Enter] key.
- [9] **Insert CleaningCart.**
- The message on the left will appear.
- [10] 
- Insert the High capacity ink pack adapter.
- Firmly insert it all the way in.
- Busy-Washing**
- The printer starts charging cleaning fluid.
- [11] **Remove Cartridges**
- When the message on the left appears, remove all High capacity ink pack adapters from the ink cartridge slots.
- Busy-Washing**
- The printer starts discharging cleaning fluid.
- [12] **[All] Discharged**
- When cleaner discharging is complete, the message to the left is displayed.

3. Steps for turning OFF the printer

[1] Prepare items required for daily maintenance.

 ["Preparing for Daily Maintenance" P. 109](#)

[2]

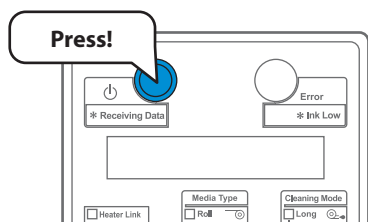

Press the power button to turn the power OFF.

- This product starts its powering off operations.
- The blue light becomes OFF.

[3]

Daily Maint. : **Start**

Press the [Enter] key.

[4]

Wash Exe ? : **Yes**

When using 4-color set, select whether or not to clean the cleaning wiper and flushing box with the cleaner.

Wash Exe ? : **No**

- "Wash Exe? No": Cleaning is not performed automatically.
- "Wash Exe? Yes": Cleaning is performed automatically.



Note

Note that the ink inside Print head is discharged by the cleaner; therefore some ink will be used.

[5]

Cleaning **** %**

The printer automatically performs the "Short" cleaning.

Wait for a while

- The carriage and cleaning wiper move to gain access to daily maintenance.

[6]

Daily Maint. : **End**

The message on the left will appear.

- You can start daily maintenance.
-  ["Performing Daily Maintenance" P. 111](#)

- After the daily maintenance is complete, press the [Enter] key.

Power Off Printer

The printer will start turning off.

[7]

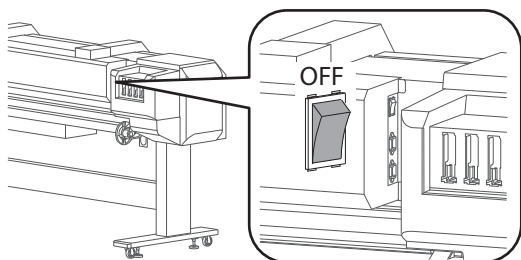

Turn OFF the power switch of Blower heater.

Performing initial charging after head cleaning

[1]

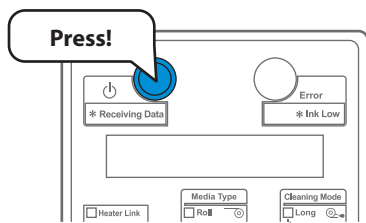

Turn the printer ON.

- Blue light becomes ON.
- The product starts initialization operations.

[2]



When the message to the left is displayed, press the [Enter] key.

[3]



Press the [-] key.

[4]



Press the [Enter] key.

[5]



When the message on the left appears, transfer the waste fluid into a container.

["Emptying waste fluid tank" P. 105](#)

[6]



The message on the left will appear.

[7]

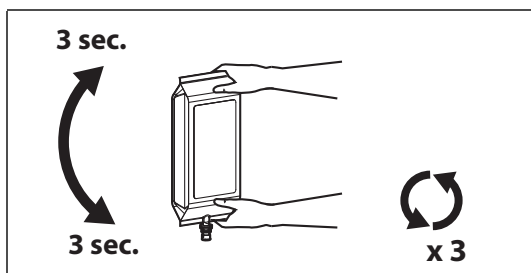

Make sure you agitate the ink bag after you prepare it.

- Turn the ink plug upward and wait for three seconds.
- Next, turn the ink plug downward and wait for three seconds.
- Repeat that three times.

[8]

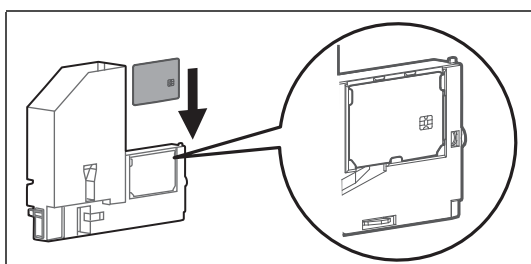

Slide the smart chip card into the tab on the High capacity ink pack adapter to install it.

[9]

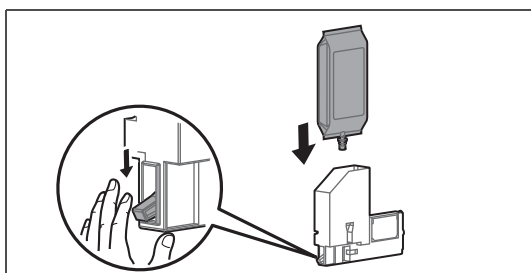

Lower the lock lever on the High capacity ink pack adapter and insert the ink bag.

- Insert all the way to the end.

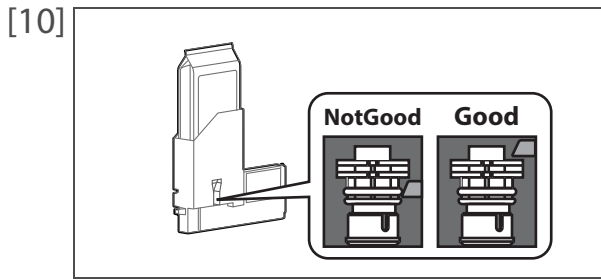

Confirm that the ink bag is inserted all the way and is locked.

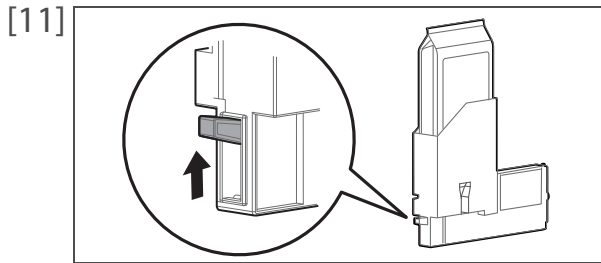

Confirm that the lock lever on the High capacity ink pack adapter is in its original position.

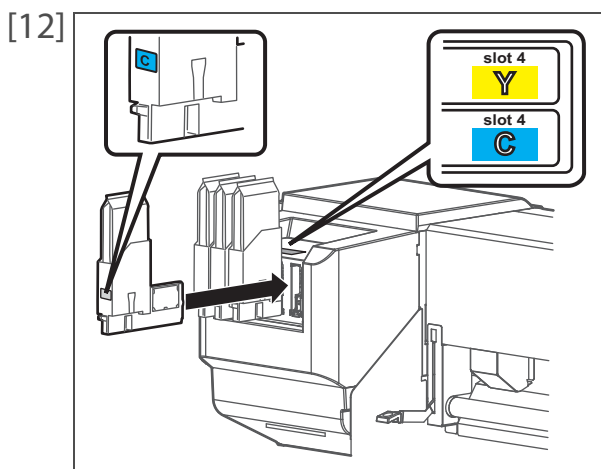

Insert the High capacity ink pack adapter.

- Match the colors of the label on the printer and the label on the High capacity ink pack adapter.
- Firmly insert it all the way in.

 **Important!**

Load the same ink color configuration as before.

Ink charging procedure after loading ink set

Ink Refill

**%

The message on the left will appear.

- Ink charging begins.

CAUTION

During ink charging, make sure:

- Not to turn OFF the printer.
- Not to unplug the power cable of the printer.
- Not to open the front cover.
- Not to open the maintenance cover.
- Not to raise the media loading lever.

Media End

When ink charging is complete, the message to the left is displayed.

Important!

If the printer perform the nozzle check printing immediately after the initial ink charge is complete, the following results may occur.

- Printed lines become blurred.
- The data is partially not printed.

In such cases, follow "[Menu 5: Cleaning](#)" P. 89 and perform "Little Charge". Then, check the print result.

If there is no improvement in the print result even after performing "Little Charge", leave the printer unused for an hour or more.

Then perform "Little Charge" again and check the print result.

If there is still no improvement, contact your local Mutoh dealer.

Chapter 4 Appendix

Messages and Error Messages	140
Status messages	140
Error message display and remedies	143
Error requiring restart	146
Troubleshooting	147
Installation and initial setup troubleshooting	147
Boot-up troubleshooting	148
Media-related troubleshooting	149
Printing-related troubleshooting	151
The media is jammed	154
Specifications of this product	156
List of specifications	156
Options / Supply list	158
Revision History	158

Messages and Error Messages



This section describes messages displayed during normal printer operation or when errors occur, and solutions to the messages.

Status messages

This section describes messages displayed during printer normal operation.

When the product is operating correctly, each operation status is displayed on the operation panel as below.

Display	Description
Ready to Print	Standby (Media is loaded).
Media End	Standby (Media is not loaded).  "Loading the media" P. 34
Receiving	Receiving data.
Converting	Analyzing data.
Printing	Under printing.
Print Remain: XXX.Xm	Displays the length of the data that has not been printed in meters for the data currently being printed.
Remain Time: XXX.Xmin	Displays the time remaining to print in minutes for the data currently being printed.
Roll Remain: XXX m	Displays the remaining length of the roll media currently set in meters.
Warming Up Skip -> Enter	Warming up Blower heater. You can print while warming up Heater. Press the [Enter] key to print.
Cleaning **%	Cleaning the head. Please wait a while.
Moving Origin Pos.	The print head is moving to the original printing position in the Origin setup menu. Please wait a while.
** Initializing **	Initializing the setting in the Initialization menu. Please wait a while.
*** Press 2sec. ***	The [Cleaning] key or the [Nozzle Check] key is pressed for less than 2 seconds. Press the key for more than 2 seconds again.
Lever Up	Set the media, and then lower the Media loading lever.
Media: Type ** OK?	Initializing the media. Please wait a while.
Media Initial	(** represents the set User type.)
Warning! *.* mm	Media thickness detection is set to Off. Check whether the thickness of the media loaded is as displayed; if it is wrong, enter the correct value.
Misuse Damage Unit >	Warns that the wrong setting for the media thickness may damage Print head. To proceed, press the [>] key on Operation panel for a while.
<E> Skip, <CAN> Detect	Press the [Enter] key to skip the media thickness detection. Press the [Cancel] key to detect the media thickness.
Perform Daily Maint.	Make sure to perform daily maintenance when prompted.  "Continuously using printer after daily maintenance" P. 118

Display	Description
Wash Exe? ***	Displayed only when you are using 4-color set. Select whether or not to wash Wiper and Flushing box with the cleaning fluid.
Perform Nzl Chk -> E	The printer has been in sleep mode for one week. Press the [Enter] key to return the printer to Normal operation. Agitate ink bags, and then perform Nozzle Check.
maintenance **%	Performing the color maintenance. Wait for a while.
Life Times [Pump]	The operational life of the pump motor has almost expired. (Continues operation) Contact your local MUTOH dealer.
Life Times [CR Motor]	The operation life CR motor has almost expired. (Continues operation) Contact your local MUTOH dealer.
Life Times [PF Motor]	The operational life of the PF motor has almost expired. (Continues operation) Contact your local MUTOH dealer.
Life Times [C Pump]	The operational life of the Circulation pump has almost expired. (Continues operation) Contact your local MUTOH dealer.
[*] Change Plug	Connector rubber for High-capacity ink pack adapter is at the end of its life. Replace Connector rubber of High-capacity ink pack adapter.  Operation manual for High-Capacity Ink Pack Adapter
Power Off	Turning OFF the printer. Wait for a while.
S/C Reading	Reading the S/C card.
Ink Circulation	Ink is circulating inside the printer.
Shake W Cartridge	Agitate the White (Wh) ink bag.
Shake KMCY Cartridge	Agitate the Black (K), Magenta (M), Cyan (C), and Yellow (Y) ink bags.
Shake ALL Cartridge	Agitate all ink bags. 4-color configuration: Agitate the Black (K), Magenta (M), Cyan (C), and Yellow (Y) ink bags. 5-color configuration: Agitate the Black (K), Magenta (M), Cyan (C), Yellow (Y), and White (Wh) ink bags.
Ink Not Expired?	Check the "Use Before" date printed on the ink bag. If the expiration date has passed, replace with a new ink bag. Press the [Enter] key to clear the message.  "Replacing ink" P. 102
Roll Near End: *m	The remaining roll paper count is almost 0. The remaining roll paper is *m.
Installed Wiper? -> No	Install the cleaning wiper.  Startup Guide
Installed Wiper? -> Yes	After installing the cleaning wiper, press the [Enter] key.
Start Ink Charge -> E	Ink charging starts. Press the [Enter] key.
Ink Comb. : * color	Select the ink type you want to use from 4-color set or 5-color set.
Wash retry? Yes	Performs cleaning using the cleaning fluid. Press the [Enter] key.







Display	Description
Insert CleaningCart.	Washing Print head. Install High capacity ink pack adapters.
Busy-Washing	<ul style="list-style-type: none"> • Initial charging, ejecting filler fluid. • Washing the print head by cleaning fluid. Please wait a while.
Remove Cartridges	Washing Print head or discharging ink. Remove High capacity ink pack adapters.
Insert Ink Cartridges	Charging the ink. Insert High capacity ink pack adapters.
Ink Refill **%	Charging the ink. Please wait a while.
Empty WasteInk -> E	Transfer the waste fluid from the waste ink tank into a container, and press the [Enter] key.  "Emptying waste fluid tank" P. 105



Error message display and remedies

This section describes error messages and remedies.

Error messages are displayed when certain failures occur during printer operation.

If an error that can be displayed occurs, the printer may display the following error messages on the operation panel and stop operation.

Display	Description
Cover Open	Front cover is open. Close Front cover.
Maint. CoverL Open	Left Maintenance cover is open. Close Maintenance cover.
Undefined Media	Media detection has failed. (Stops operation) Reload the media.
Media Slant	Media is fed obliquely. (Stops operation) Reload the media.
Obstacle Detection -> E	An obstacle has been detected. (Stops operation) Remove the obstacle, and press the [Enter] key.  "When the sensor detects obstacles" P. 27
PrintRestart? No	To cancel the job, press the [Enter] key.
PrintRestart? Yes	To resume the job, press the [Enter] key.
Change: X.X mm ->	Enter the value to adjust the head height for the media, then press the [Enter] key. When you press the [>] key on the Operation panel, the setting value (0.5) and the input adjustment value (0.1) are displayed, as in "Thick. + Adj: 0.5 + 0.1".
Is it preserved? No	The current thickness adjustment value in the user type remains unchanged (the value entered is enabled only for the job currently printing).
Is it preserved? Yes	The current thickness adjustment value in the user type is overwritten with the value entered.
End Of Roll	The roll media has run out. (Stops operation) Load a new roll media.  "Loading the media" P. 34
[*****] Ink Low	Slot * ink is low. Get a replacement bag ready.  "Replacing ink" P. 102
[*****] Ink End	Ink has run out. (Stops operation) Replace with a new ink bag.  "Replacing ink" P. 102
[*****] No Cartridge	High capacity ink pack adapter is not inserted. (Stops operation) Insert High capacity ink pack adapter.
[*****] Discharged	Ink is not filled. Perform initial ink charging.  "Performing initial charging after head cleaning" P. 136
Full WasteInkTank	The waste fluid tank has become full. (Stops operation) Immediately transfer the waste fluid into a container.  "Emptying waste fluid tank" P. 105
[*****] S/C ReadErr	Reading S/C Card has been failed. Insert S/C Card again.

Display	Description
[*****] S/C Col.Err	High capacity ink pack adapters are inserted in wrong slots. Insert High capacity ink pack adapters correctly again.
[*] S/C Ink Err	The ink cannot be used for this printer. Contact your local MUTOH dealer.
[*] S/C CodeErr	Inserted ink bag is not a proper one. Contact your local MUTOH dealer.
[*] Broken Chip	S/C Card has been broken. Insert new ink bag.
[*] Check Ink	High capacity ink pack adapters were not recognized correctly. Insert High capacity ink pack adapters correctly again. Contact your local MUTOH dealer.
[*] Reseat Cart.	You need to reinsert the high capacity ink pack adapters due to the smart chip card reading failure.  "Replacing ink" P. 102
Heater Error <E> Print <CAN> Cancel	The Blower heater temperature has not reached the set temperature within the specified time. <ul style="list-style-type: none"> • Press the [Enter] key to print. Print result is not guaranteed. • Press the [Cancel] key to cancel printing. Turn Blower heater OFF and restart. If this still does not clear the problem, contact your local MUTOH dealer.
Ready to Print/PFErr	PF origin sensor could not detect the origin position for feeding. You can still print, but print quality is not guaranteed. If this still does not clear the problem, contact your local MUTOH dealer.
ObstacleDetection->E	An obstacle has been detected. Press the [Enter] key, and reset the media in place.  "Loading the media" P. 34
Obstacle Sensor Err	An error occurred in the obstacle sensor. (Stops operation) Use your hand to move the sensor and check that it can move up and down properly. If this still does not clear the problem, contact your local MUTOH dealer.
Replace to Ink	After ink has been replaced with cleaning fluid, printing is not possible. To perform printing, use "Mnt.6: Wash Replace" and replace cleaning fluid with ink.  "Maintenance 6: Wash Replace" P. 92

 **Note**

- [*****] in the error message indicates the target ink cartridge slot.
- If "Ink End" and "No Cartridge" occur at the same time, "No Cartridge" message has priority to be displayed.

Smartchip recovery

When the following message is prompted on the operation panel, a smartchip error such as broken chip may have occurred in the ink cartridge.

Check that the correct color is inserted in the cartridge slot and perform smartchip recovery.

This will allow you to continue to print.

To perform smartchip recovery, do one of the followings according to the message appeared.

Display	Description
[*****] S/C Recog. Err.	An ink cartridge that needs smartchip recovery may have been installed. Remove the ink cartridge and reload it. If the printer is still unable to read it, install a new ink cartridge. <ul style="list-style-type: none">• If a message "[***] Check Color ->E" appears after the ink cartridge is reloaded, follow the message "[***] Check Color ->E" to operate.
[***] Check Color ->E	An ink cartridge that needs smartchip recovery may have been installed. Check that the ink color of the cartridge inserted is correct. <ul style="list-style-type: none">• In case of wrong color insertion, load a correct ink color cartridge.• If color is correct, press the [Enter] key. The printer will perform smart chip recovery and will continue to print.

Note

- During smartchip recovery execution, the ink cartridge being recovered blinks in the ink status menu.

 ["Set 14: Ink Status" P. 84](#)

Error requiring restart

An error requiring restart is displayed if a fatal operational failure such as the following occurs.

- When an obstacle that prevents printing occurs.
- When a problem occurs with the electrical circuit (PCB, motor, sensor, etc.) of the printer.
- When a failure in the printer control program occurs.

If an error requiring restart occurs, the printer stops operating after performing the following operations.

1. The drive power automatically shuts down.
2. All lamps on the operation panel blink, and the buzzer rings continuously.
3. The error message is displayed on the operation panel.

Pressing any key on the operation panel stops the beeping.

For an error requiring restart, operation will return to normal after removing the cause of the error and restarting the printer.

If the same error continues to be displayed, contact the your local MUTOH dealer.

Be sure to tell us the code no. of the error message when you contact us.

Display	Description
E***Err []	A problem that does not have a remedy has occurred. <ol style="list-style-type: none">1. Remove obstacles such as paper scraps in the drive system.2. Confirm that the replaced items are correctly attached.3. Turn the power button off. Wait a short while, then turn the power button on, to restart the printer.

Note

- "****" in the error message is the code no. that indicates what type of error occurred.
- The command code representing the error occurred may be indicated in [].

Troubleshooting

This section describes undisplayed malfunctions and failures of the printer, possible causes and countermeasures.

Note

- The current status and error information of your printer can be checked from the Printer Status tab > Status Information on MSM.
If your printer is not operating correctly, check this Status Information first.
- Make sure to use the latest version of MSM.
To check the latest available version, go to Help > Version > Check for updates on MSM.
If old version is installed in your computer, download the latest version from MUTOH Club.
 MUTOH Status Monitor Operation Manual

Installation and initial setup troubleshooting

Cannot perform the initial ink charging.

Is the front cover, or the maintenance cover open?

- Close the front cover, or the maintenance cover.

Is the media loading lever raised?

- Lower the media loading lever.

Are High capacity ink pack adapters inserted all the way into the printer?

- Make sure High capacity ink pack adapters are all inserted properly.

Ink does not come out after ink charging.

Is the ink too cold?

- Leave the ink at room temperature for at least three hours, and perform cleaning several times.

Is the power turned OFF during ink charging?

- Turn the power ON again and continue ink charging.

Nozzle missing occurs after initial ink charging.

Did you perform head cleaning?

- Perform cleaning, then, check the print result.

- If there is no improvement in the print result even after performing cleaning, leave the printer unused for an hour or more.
Then perform cleaning or "Little Charge" again and check the print result.

- If there is still no improvement, contact your local Mutoh dealer.

 ["Head cleaning" P. 120](#)

MSM or RIP cannot access to the printer.

Is Ethernet cable connected correctly?

- Securely connect the Ethernet cable to the Ethernet Port.

Are the network settings configured correctly?

- Configure the network settings correctly.

Do the printer's network settings match the computer's settings?

- Match this product's network settings with the computer side environment.

 ["Connecting to a Computer" P. 19](#), ["Initial 3: IP Address" P. 94](#), ["Initial 4: Subnet Mask" P. 95](#), ["Initial 5: Gateway" P. 95](#)

Boot-up troubleshooting

Does not work at all after power activation / after loading the media.

Is the power cable connected to the plug?

- Connect the power cable.

Does the AC power supply provide the specified voltage?

- Connect the cable to another outlet.

Is the front cover, or the maintenance cover open?

- Close the front cover, or the maintenance cover.

Is the media loading lever raised?

- Lower the media loading lever.

Is the media loaded correctly?

- Load the media correctly.

Is the High capacity ink pack adapter inserted?

- Insert the High capacity ink pack adapter.

Do you use the printer within recommended environmental conditions?

- Make sure to use the printer within the specification range.

Is there any error message displayed on MSM?

- Go to the Printer Status tab in MSM and check that if any error message is displayed in the Status Information.

 ["Loading the media" P. 34](#), "Ensuring a suitable place for installation" of the "Startup Guide" on page P.5

The media slips, is torn / crumpled during initialization.

Is the media loaded correctly? - Load the media correctly.
Are there any foreign materials such as torn paper attached to Pressurizing rollers? - Clean Pressurizing rollers.
Do you use the printer within recommended environmental conditions? - Make sure to use the printer within the specification range.
Are any curls or warps present on your media? - Set the media holder at both edges of the media. - Check that you select the appropriate vacuum fan setting.
Are you using creased, damaged, torn or curled media? - Replace the media.



Note

If the media is jammed or torn, remove it according to "The media is jammed" P.153.

The printer does not detect the media.

Is the media loaded correctly? - Load the media correctly.
Is the media loaded at an angle? - Load the media straight.
Do you use the printer within recommended environmental conditions? - Make sure to use the printer within the specification range.
Did you load the media which has been printed before? - Use a new media.

 ["Loading the media" P. 34](#), ["Inside cleaning" P. 122](#), ["After loading the media..." P. 37](#), ["4: Vacuum Fan" P. 72](#), ["The media is jammed" P. 154](#), "Ensuring a suitable place for installation" of the "Startup Guide" on page P.5

Media jams frequently occur.

Do you use the printer within recommended environmental conditions?

- Make sure to use the printer within the specification range.

Are any curls or warps present on your media?

- Set the media holder at both edges of the media.

- Check that you select the appropriate vacuum fan setting.

Are you using creased, damaged, torn or curled media?

- Replace the media.



Note

If the media is jammed or torn, remove it according to "The media is jammed" P.153.

The media skews during printing.

Is the media loaded correctly?

- Load the media correctly.

"Ensuring a suitable place for installation" of the "Startup Guide" on page P.5, ["After loading the media..." P. 37](#), ["4: Vacuum Fan" P. 72](#), ["The media is jammed" P. 154](#), ["Loading the media" P. 34](#)

The printer does not print.

Is Ethernet cable connected correctly?

- Securely connect the Ethernet cable to the Ethernet Port.

Is there any error message displayed on MSM?

- Go to the Printer Status tab in MSM and check that if any error message is displayed in the Status Information.

Smears or missing area partially appears on the prints.

Are any curls or warps present on your media?

- Set the media holder at both edges of the media.

- Check that you select the appropriate vacuum fan setting.

Does the printer heater deform your media?

- If the heater deforms the media loaded to the printer before printing, go to the "Start Feed" menu to increase the media feeding amount.

Does the media contain moisture or are you using the creased or wrinkled media?

- Replace it with the new media.

The printing position is incorrect (some parts of the media cannot be printed on).

Is the media loaded correctly?

- Load the media correctly.

Did you set up the origin?

- Cancel or reset the settings of the origin.

Printing is blurred.

Is the media printed on the printing surface?

- Check the printing surface of the media and set it correctly.

Does the blower heater work properly?

- Check that the blower heater is set to the appropriate setting.

Did you perform Print quality adjustment?

- Perform Print quality adjustment.

Did you perform Media feed adjustment?

- Perform Media feed adjustment.

 ["Connecting to a Computer" P. 19](#), ["After loading the media..." P. 37](#), ["***>4: Vacuum Fan" P. 72](#), ["Set 17: Start Feed" P. 85](#), ["Loading the media" P. 34](#), ["Set 5: Origin" P. 78](#), ["Heater Operation panel" P. 12](#), ["***>2: Adjust Print" P. 64](#), ["***>3: PF Adjust" P. 68](#)

White or black lines appear on printed media.

Is the media loaded correctly? - Load the media correctly.
Does the media contain moisture or are you using the creased or wrinkled media? - Replace it with the new media.
Are Nozzles in good condition? - Perform Nozzle check. Then if nozzle missing is found, conduct cleaning.
Did you perform Print quality adjustment? - Perform Print quality adjustment.
Did you perform Media feed adjustment? - Perform Media feed adjustment.

Printing lines are not straight / are duplicated or patchy.

Are Nozzles in good condition? - Perform Nozzle check. Then if nozzle missing is found, conduct cleaning.
Did you agitate ink in the bag? - When "Shake XX Cartridge" message appears on the operation panel, agitate ink in the bag.
Did you perform Print quality adjustment? - Perform Print quality adjustment.
Did you perform Media feed adjustment? - Perform Media feed adjustment.
Is Ink bag within the validity period? - Use a non-expired ink bag.

 ["Loading the media" P. 34](#), ["Nozzle check and cleaning" P. 43](#), ["***>2: Adjust Print"> P. 64](#), ["***>3: PF Adjust" P. 68](#)

Printed color is not accurate.

Are Nozzles in good condition?

- Perform Nozzle check.
Then if nozzle missing is found, conduct cleaning.

Did you install an ink bag on each High capacity ink pack adapter with correct ink color of S/C card?

- Check that the ink color written on S/C card matches the ink color of ink bag installed on each High capacity ink pack adapter.
- If it does not match, contact your local Mutoh dealer.

Did you agitate ink in the bag?

- When "Shake XX Cartridge" message appears on the operation panel, agitate ink in the bag.



Note

If variations in color on the print is noticeable, set the Color Maintenance function to ON.

Nozzle missing remains after head cleaning.

Is there any ink stains or deposits on the cleaning wiper or circumference of the print head?

- Perform head cleaning or "Little Charge" again and check the nozzle check print.
- Perform Daily Maintenance and check the nozzle check print.
- The problem still persists, contact your local Mutoh dealer.

Did you select an appropriate cleaning setting?

- If nozzle missing still persists after attempting Normal Cleaning or Long Cleaning two or three times, perform "Little Charge".

 ["Nozzle check and cleaning" P. 43](#), ["Maintenance 7: Color Maintenance" P. 93](#), ["Daily Maintenance" P. 108](#),
["Menu 5: Cleaning" P. 89](#)

The media is jammed

When the media is jammed in the printer, follow the procedure below to remove it.

Steps

[1]

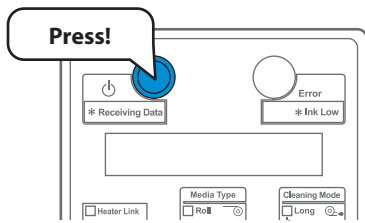

Turn the printer OFF.

[2]

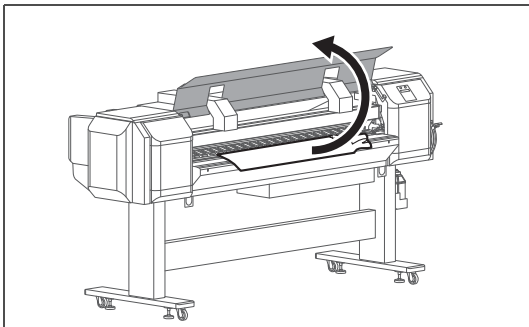

Open the front cover.

[3]

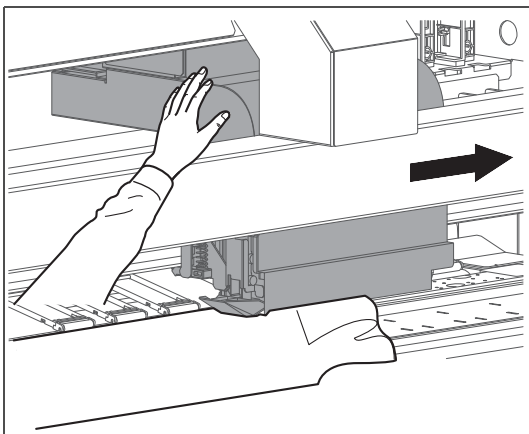

Move the carriage from the top of the media.

[4]

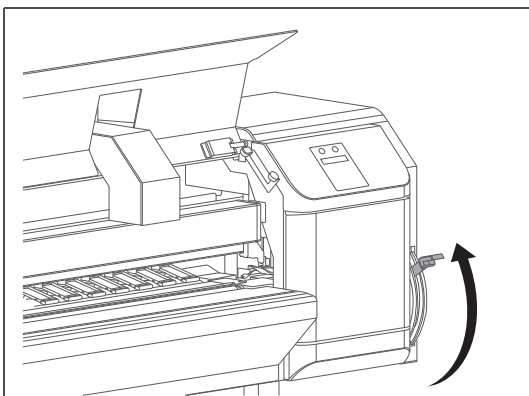

Raise the media loading lever.

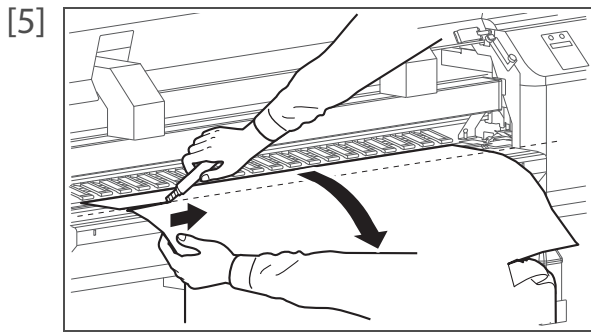

[5] Pull the media towards you, and cut the torn part with cutting tools such as a razor blade.

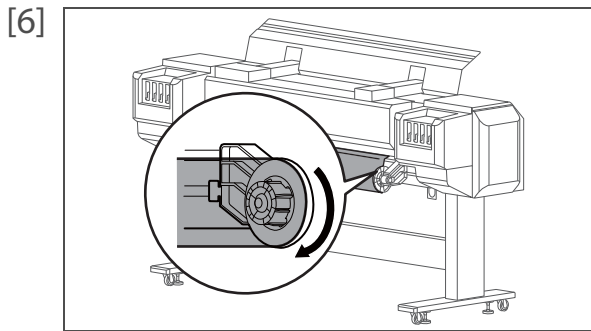

[6] Rewind the media a little by rolling Flange on Roll media holder.

[7] If paper dust or pieces of paper remain inside the printer, remove them.

[8] Turn the printer ON.

[9] Put the printer into the daily maintenance mode and clean the head strike prevention sensor and around the print head.

 ["Putting the printer into the Daily maintenance mode" P. 118](#), ["How to clean the head strike prevention sensor" P. 115](#)

 **Important!**

If any defect is found on the head strike prevention sensor or print head, please contact your local MUTOH dealer.

[10] Perform Nozzle Check.

 ["Nozzle check and cleaning" P. 43](#)

- If there is nozzle missing, go to ["Cleaning steps" P. 45](#).
- If all lines are clearly printed, you can start printing.

Specifications of this product

List of specifications

Model Name	VJ-1627MH	
Print method	On demand piezo method	
Drive method	Firmware servo / DC motor drive	
Media feed method	Multipoint pressurizing Grid roller system	
Media fixing system	Pressurization roller down system by manual lever	
Conditions of usable media	Roll media	Outer diameter: Φ 150 mm or less
		Tube diameter: 2 inches or 3 inches
		Weight: 30 kg or less
	Rigid media	Maximum length: 1,200 mm
		Minimum length: 200 mm
		Weight: 15 kg or less
Roll / Rigid media	Maximum width: 1,625 mm	
	Minimum width: 182 mm	
	Maximum thickness: 16 mm (warpage of less than 1 mm)	
Maximum print width	1,615 mm	
Maximum print length	200 m	
Media cut system	Horizontal manual cut system	
Head height adjustment	Automatic height adjustment	
CPU	64bit RISC CPU	
Memory	384 MB	
Interface	Ethernet (10BASE-T / 100BASE-TX)	
Waste fluid tank	Fixed to the body type, capacity 2,000 ml, waste fluid discharge by users	
Ink	Color	4-color (Black, Cyan, Magenta, Yellow) 5-color (Black, Cyan, Magenta, Yellow, White, Cleaner)
	Type	500 ml ink bag

Environmental conditions	Printer Operation Environment	Temperature 20 to 28 °C, humidity 40 to 60% No condensation
	Printer Accuracy Guaranteed Environment	Temperature 22 to 28 °C, humidity 40 to 60% No condensation
	Printer Storage Environment	Storage without ink charging: up to 6 months Temperature -20 to +60 °C, humidity 20 to 80% No condensation Storage with ink charging: up to 30 days (Perform the Daily Maintenance in the operation manual) Temperature 5 to +30 °C, humidity 20 to 80% No condensation
Power supply specifications	Printer	Voltage: AC 100V to 240V ±10% Frequency: 50/ 60Hz ±1Hz Capacity: No less than 3 A
	Blower Heater	Voltage: AC 100V to 120V ±10% / AC 200V to 240V ±10% Frequency: 50/ 60Hz ±1Hz Capacity <ul style="list-style-type: none"> • Heater 1: No less than 10 A (AC 100V to 120V) • Heater 1: No less than 10 A (AC 200V to 240V) • Heater 2: No less than 10 A (AC 100V to 120V) • Heater 2: No less than 0 A (AC 200V to 240V)
Power consumption	Power off	1.0 W or below
	Standby	Printer: 40 W or below Blower Heater: 25.4 W or below
	Warming up	Printer: 40 W or below Blower Heater: 2,400 W or below
	Operation	Printer: 300 W or below Blower Heater: 2,200 W or below
Current consumption	100V to 120V	18.0 A or below
	200V to 240V	10.0 A or below
External dimensions	Height	1,302 mm (Size of printer when the front cover is opened: 1,529 mm)
	Width	2,983 mm
	Depth	818 mm (When the media-feed table is installed: 2,730 mm)
Weight	Main body	167.5 kg
	Stand	33 kg

Options / Supply list

For more information about the options and the supply items, contact your local MUTOH dealer.

Revision History

Date	Version	Manual code	Supported Firmware
2018.7	00	VJ1627MHE-A-00	V.1.00
2019.2	01	VJ1627MHE-A-01	V.1.01
2020.3	02	VJ1627MHE-A-02	V.1.01
2020.12	03	VJ1627MHE-A-03	V.1.03 or later

MUTOH